

## Socket Weld Union

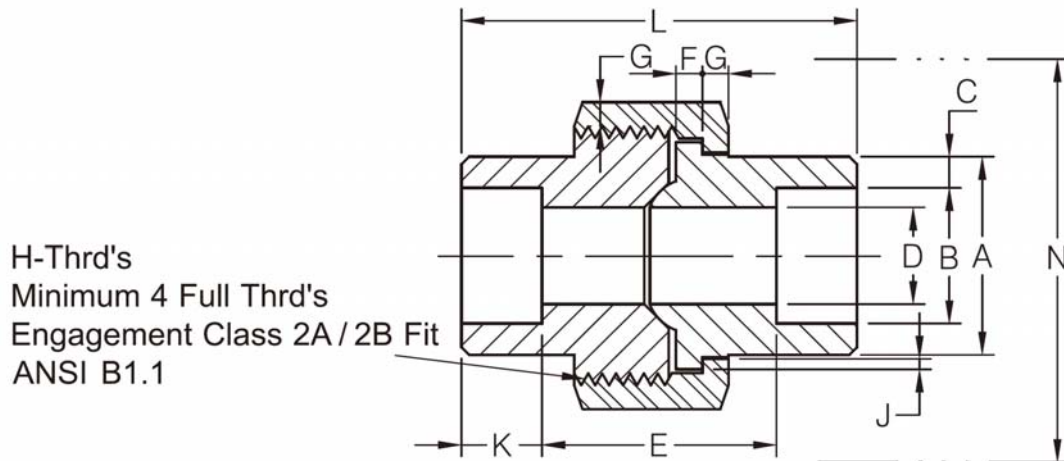

### 3000Lb

Nom. Pipe Size	Pipe End (Min) A	Socket Bore Dia. B <sup>(1)</sup>	Socket Wall (Min) C	Water Way Bore D <sup>(1)</sup>	Laying Length E <sup>(1)</sup>	Male Flange (Min) F	Nut (Min) G	Threads Per 25.4mm H	Bearing (Min) J	Depth of Socket (Min) K	Length Assem. Nom. L	Clear Assem. Nut N
1/8"	21.8	11.18 10.67	3.18	7.59 6.07	22.4 19.1	3.18	3.18	16	1.24	9.7	41.4	50.8
1/4"	21.8	14.61 14.10	3.30	10.01 8.48	22.4 19.1	3.18	3.18	16	1.24	9.7	41.4	50.8
3/8"	25.9	18.03 17.53	3.51	13.28 11.76	26.9 20.6	3.43	3.43	14	1.37	9.7	46.0	55.9
1/2"	31.2	22.23 21.73	4.09	16.56 15.04	26.9 20.6	3.68	3.68	14	1.50	9.7	49.0	58.4
3/4"	37.1	27.56 27.05	4.27	21.69 20.17	31.8 25.4	4.06	4.06	11	1.68	12.7	56.9	66.0
1"	45.5	34.29 33.78	4.98	27.41 25.88	34.3 26.2	4.57	4.45	11	1.85	12.7	62.0	78.7
1-1/4"	54.9	43.05 42.55	5.28	35.81 34.29	40.6 32.5	5.33	5.21	11	2.13	12.7	71.1	94.0
1-1/2"	61.5	49.15 48.64	5.54	41.66 40.13	42.2 34.0	5.84	5.59	10	2.31	12.7	76.5	111.8
2"	75.2	61.62 61.11	6.05	53.26 51.74	45.5 37.3	6.60	6.35	10	2.69	15.7	86.1	132.1
2-1/2"	91.7	74.45 73.81	7.67	64.24 61.19	61.7 52.1	7.49	7.11	8	3.07	15.7	102.4	149.9
3"	109.2	90.42 89.79	8.31	79.45 76.40	63.8 53.6	8.26	8.00	8	3.53	15.7	109.0	175.3

(1) Upper and lower values for each size are the respective maximum and minimum dimensions.

(2) Dimensions in accordance with MSS SP-83-2014.

## Socket Weld Union

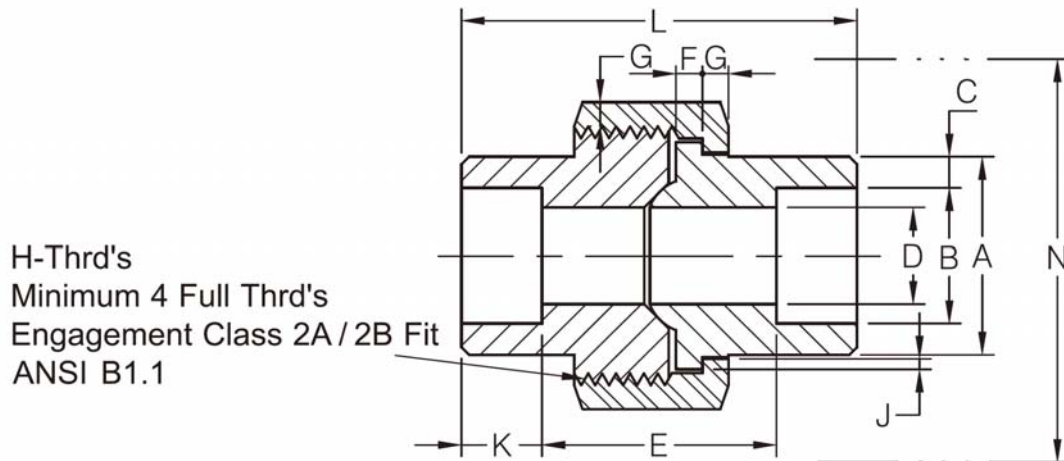

### 6000Lb

Nom. Pipe Size	Pipe End (Min) A	Socket Bore Dia. B <sup>(1)</sup>	Socket Wall (Min) C	Water Way Bore D <sup>(1)</sup>	Laying Length E <sup>(1)</sup>	Male Flange (Min) F	Nut (Min) G	Threads Per 25.4mm H	Bearing (Min) J	Depth of Socket (Min) K	Length Assem. Nom. L	Clear Assem. Nut N
1/8"	21.8	11.18 10.67	3.43	4.80 3.20	22.4 19.1	3.18	3.18	16	1.24	9.7	41.4	50.8
1/4"	25.9	14.61 14.10	4.01	7.11 5.59	26.9 20.6	3.43	3.43	14	1.37	9.7	46.0	55.9
3/8"	31.2	18.03 17.53	4.37	9.88 8.36	26.9 20.6	3.68	3.68	14	1.50	9.7	49.0	58.4
1/2"	37.1	22.23 21.72	5.18	12.55 11.02	31.8 25.4	4.06	4.06	11	1.68	9.7	56.9	66.0
3/4"	45.5	27.56 27.05	6.05	16.31 14.78	34.3 26.2	4.57	4.45	11	1.85	12.7	62.0	78.7
1"	54.9	34.29 33.78	6.93	27.41 25.88	40.6 32.5	5.33	5.21	11	2.13	12.7	71.1	94.0
1-1/4"	61.5	43.05 42.55	6.93	30.23 28.70	42.2 34.0	5.84	5.59	10	2.31	12.7	76.5	111.8
1-1/2"	75.2	49.15 48.64	7.80	34.75 33.22	45.5 37.3	6.60	6.35	10	2.69	12.7	86.1	132.1
2"	91.7	61.62 61.11	9.50	43.61 42.09	61.7 52.1	7.49	7.11	8	3.07	15.7	102.4	149.9
2-1/2"	109.2	74.45 73.81	10.39	54.74 53.21	63.8 53.6	8.26	8.00	8	3.53	15.7	109.0	175.3

(1) Upper and lower values for each size are the respective maximum and minimum dimensions.

(2) Dimensions in accordance with MSS SP-83-2014.