

## Street Elbows Threaded

Threaded End ASME B16.11-2009 (Revision of ASME B16.11-2005)

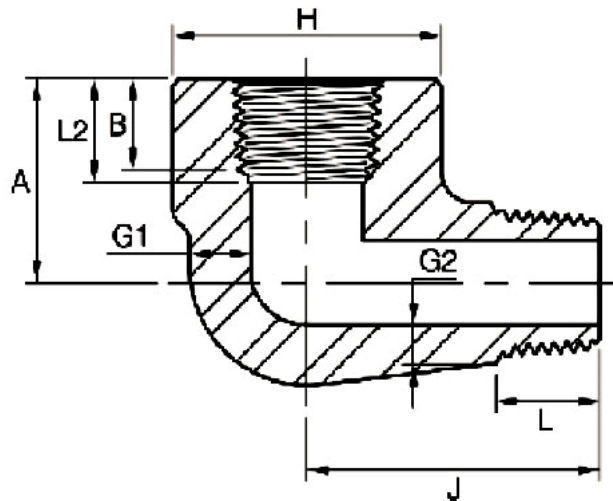

DN	Nom. Pipe Size	H		A		J		G1 (Min.)		G2 <sup>(1)</sup> (Min)		B <sup>(2)</sup> (Min)	L2 <sup>(2)</sup> (Min)	L (Min)
		3000	6000	3000	6000	3000	6000	3000	6000	3000	6000			
6	1/8"	19	25	19	22	25	32	3.18	5.08	2.74	4.22	6.4	6.7	10.0
8	1/4"	25	32	22	25	32	38	3.30	5.66	3.22	5.28	8.1	10.2	11.0
10	3/8"	32	38	25	28	38	41	3.50	6.98	3.50	5.59	9.1	10.4	13.0
15	1/2"	38	44	28	35	41	48	4.09	8.15	4.16	6.53	10.9	13.6	14.0
20	3/4"	44	51	35	44	48	57	4.32	8.53	4.88	6.86	12.7	13.9	16.0
25	1"	51	62	44	51	57	66	4.98	9.93	5.56	7.95	14.7	17.3	19.0
32	1-1/4"	62	70	51	54	66	71	5.28	10.59	5.56	8.48	17.0	18.0	21.0
40	1-1/2"	70	84	54	64	71	84	5.56	11.07	6.25	8.89	17.8	18.4	21.0
50	2"	84	102	64	83	84	105	7.14	12.09	7.64	9.70	19.0	19.0	22.0

(1) Dimensions in Millimeters.

(2) Dimension B is minimum length of perfect thread. The length of useful thread (B plus threads with fully formed roots and flat crests) shall not be less than L2 (effective length of external thread) required by American National Standard for pipe threads (ANSI/ASME B1.20.1)