

Butt Weld Pipe Fittings



Butt Weld Fittings

Dimension : ANSI B16.9, B16.25, B16.28, MSS SP-43, SP-48, SP-59
Material Spec. : ASTM A403, A240, A312, A234 WPB
Material Grades : 304, 304L, 316, 316L, CARBON STEEL



90° ELBOW



45° ELBOW



180° ELBOW



EQUAL TEE



REDUCING TEE



CAP



CON. REDUCER



ECC. REDUCER



STUB END

STAINLESS & CARBON STEEL BUTT-WELDING FITTINGS

WELLGROW INDUSTRIES CORP.

Long and Short Radius 45°/ 90° Elbows

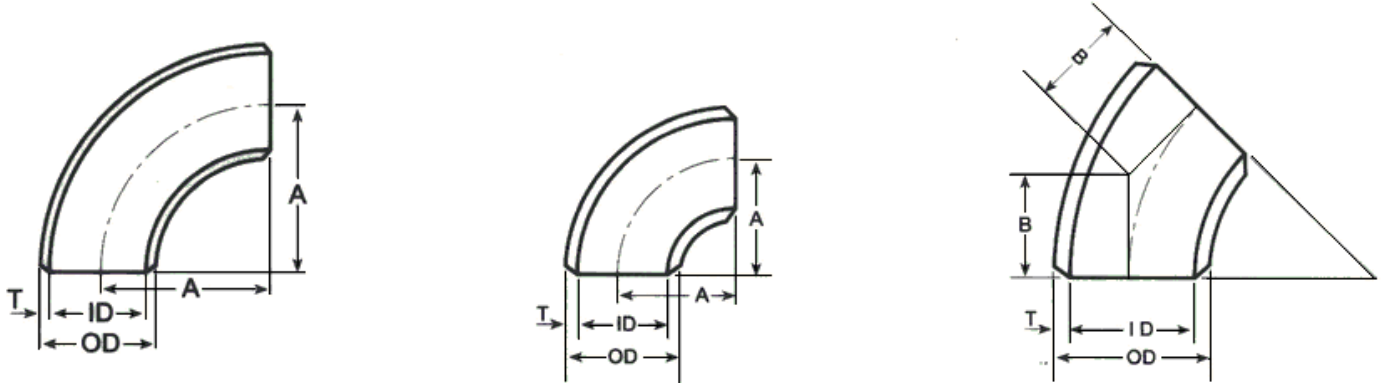

ANSI B16.9 B16.28 (in mm)
* Wellgrow's standard.

Nominal Pipe Size (NPS)	Outside Diameter at Bevel D	Center to End			
		Long Radius Elbows		Short Radius Elbows	
		90 degree. A	45 degree B	90 degree A	45 degree B
1/2	21.3	38.1	15.7	-	-
3/4	26.7	38.1	19.1	-	-
1	33.4	38.1	22.4	25.4	-
1-1/4	42.2	47.8	25.4	31.8	-
1-1/2	48.3	57.2	28.4	38.1	-
2	60.3	76.2	35.1	50.8	-
2-1/2	73.0	95.2	44.4	63.5	-
3	88.9	114.3	50.8	76.2	31.6
3-1/2	101.6	133.4	57.2	88.9	36.8
4	114.3	152.4	63.5	101.6	42.1
5	141.3	190.5	79.2	127.0	52.6
6	168.3	228.6	95.2	152.4	63.4
8	219.1	304.8	127.0	203.2	84.2
10	273.1	381.0	158.8	254.0	105.2
12	323.9	457.2	190.5	304.8	126.3
14	355.6	533.4	222.2	355.6	147.3
16	406.4	609.6	254.0	406.4	168.3
18	457.2	685.8	285.8	457.2	189.4
20	508.0	762.0	317.5	508.0	210.4
22	558.8	838.2	342.9	558.8	231.5
24	609.6	914.4	381.0	609.6	252.5
26	660.4	990.6	406.4	660.4	273.5
28	711.2	1066.8	438.2	711.2	294.6
30	762.0	1143.0	469.9	762.0	315.6
32	812.8	1219.2	501.6	812.8	378.1
34	863.6	1295.4	533.4	863.6	357.7
36	914.4	1371.6	565.2	914.4	378.8
38	965.2	1447.8	599.9	-	-
40	1016.0	1524.0	632.0	1016.0	420.8
42	1066.8	1600.2	660.4	1066.8	441.9
44	1117.6	1676.4	695.5	1117.6	462.9
46	1168.4	1752.6	726.9	-	-
48	1219.2	1828.8	759.0	1219.2	505.0
52*	1320.8	-	-	1320.8	547.1
54*	1371.6	2057.4	852.2	1371.6	568.1
56*	1422.4	2133.6	883.8	1422.4	589.2
60*	1524.0	2286.0	946.9	1524.0	631.3
66*	1676.4	2514.6	1041.6	-	-
68*	1727.0	2591	1073	1727	-
72*	1829.0	2743	1137	1829	-
76*	1930.0	2896	1199	1930	-
80	2032.0	3048	1263	2032	-

STAINLESS & CARBON STEEL BUTT-WELDING FITTINGS

WELLGROW INDUSTRIES CORP.

Long and Short Radius 180° Elbows

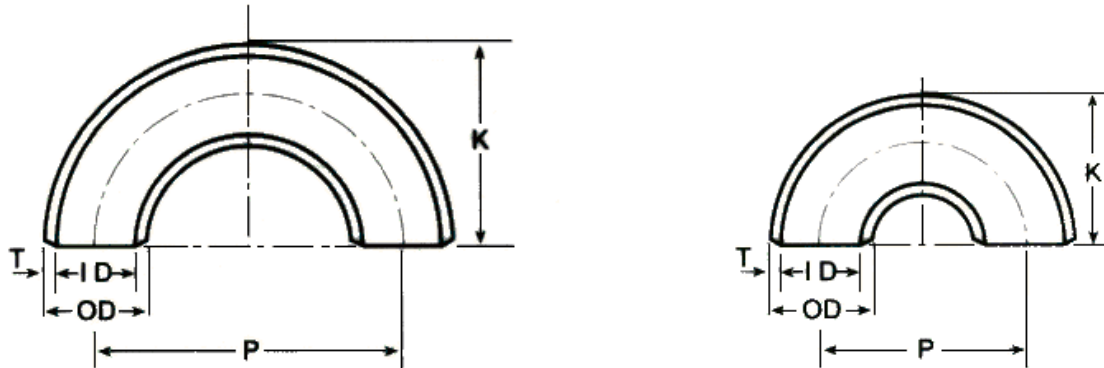

ANSI B16.9 B16.28 (in mm)

Nominal Pipe Size (NPS)	Outside Diameter at Bevel D	Long Radius Elbows		Short Radius Elbows	
		Center to Center. P	Back to Face K	Center to Center. P	Back to Face K
1/2	21.3	76.2	47.8	-	-
3/4	26.7	76.2	50.8	-	-
1	33.4	76.2	55.6	50.8	41.1
1-1/4	42.2	95.2	69.8	63.5	52.3
1-1/2	48.3	114.3	82.6	76.2	62.0
2	60.3	152.4	106.4	101.6	81.0
2-1/2	73.0	109.5	131.8	127.0	100.1
3	88.9	228.6	158.8	152.4	120.7
3-1/2	101.6	266.7	184.2	177.8	139.7
4	114.3	304.8	209.6	203.2	158.8
5	141.3	381.0	261.9	254.0	196.9
6	168.3	457.2	312.7	304.8	236.5
8	219.1	609.6	414.3	406.4	312.7
10	273.1	762.0	517.7	508.0	390.7
12	323.9	914.4	619.3	609.6	466.9
14	355.6	1066.8	711.2	711.2	533.4
16	406.4	1219.2	812.8	812.8	609.6
18	457.2	1371.6	914.4	914.4	685.8
20	508.0	1524.0	1016.0	1016.0	762.0
22	558.8	1676.4	1117.6	1117.6	838.2
24	609.6	1828.8	1219.2	1219.2	914.4

STAINLESS & CARBON STEEL BUTT-WELDING FITTINGS

WELLGROW INDUSTRIES CORP.

Equal and Reducing Tees

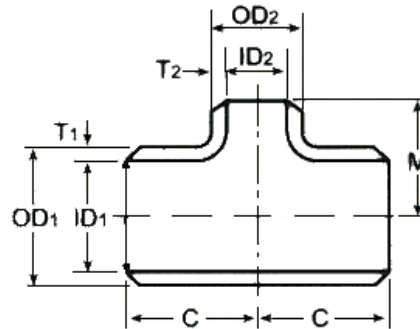
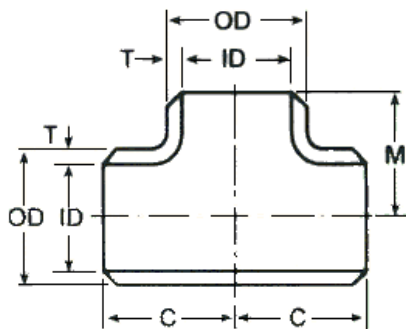

MSS SP-75 ANSI B16.9 (in mm)
* Wellgrow's standard.

Nominal Pipe Size (NPS)	Outside Diameter At Bevel D		Center to End	
	Run	Outlet	Run C	Outlet (1) M
1/2 x 1/2	21.3	21.3	25.4	25.4
1/2 x 3/8		17.1		25.4
1/2 x 1/4		13.7		25.4
3/4 x 3/4	26.7	26.7	28.4	28.4
3/4 x 1/2		21.3		28.4
3/4 x 3/8		17.1		28.4
1 x 1	33.4	33.4	38.1	38.1
1 x 3/4		26.7		38.1
1 x 1/2		21.3		38.1
1-1/4 x 1-1/4	42.2	42.2	47.8	47.8
1-1/4 x 1		33.4		47.8
1-1/4 x 3/4		26.7		47.8
1-1/4 x 1/2		21.3		47.8
1-1/2 x 1-1/2	48.3	48.3	57.2	57.2
1-1/2 x 1-1/4		42.2		57.2
1-1/2 x 1		33.4		57.2
1-1/2 x 3/4		26.7		57.2
1-1/2 x 1/2		21.3		57.2
2 x 2	60.3	60.3	63.5	63.5
2 x 1-1/2		48.3		60.5
2 x 1-1/4		42.2		57.2
2 x 1		33.4		50.8
2 x 3/4		26.7		44.4
2 x 1/2*		21.3		
2-1/2 x 2-1/2	73.0	73.0	76.2	76.2
2-1/2 x 2		60.3		69.8
2-1/2 x 1-1/2		48.3		66.5
2-1/2 x 1-1/4		42.2		63.5
2-1/2 x 1		33.4		57.2
3 x 3	88.9	88.9	85.9	85.9
3 x 2-1/2		73.0		82.6
3 x 2		60.3		76.2
3 x 1-1/2		48.3		73.2
3 x 1-1/4		42.2		69.8
3 x 1*		33.4		
3-1/2 x 3-1/2	101.6	101.6	95.2	95.2
3-1/2 x 3		88.9		91.9
3-1/2 x 2-1/2		73.0		88.9
3-1/2 x 2		60.3		82.6
3-1/2 x 1-1/2		48.3		79.2

Nominal Pipe Size (NPS)	Outside Diameter At Bevel D		Center to End	
	Run	Outlet	Run C	Outlet (1) M
4 x 4	114.3	114.3	104.6	104.6
4 x 3-1/2		101.6		101.6
4 x 3		88.9		98.6
4 x 2-1/2		73.0		95.2
4 x 2		60.3		88.9
4 x 1-1/2		48.3		85.9
4 x 1-1/4		42.2		
4 x 1*		33.5		
5 x 5	141.3	141.3	124.0	124.0
5 x 4		114.3		117.3
5 x 3-1/2		101.6		114.3
5 x 3		88.9		111.3
5 x 2-1/2		73.0		108.0
5 x 2		60.3		104.6
5 x 1-1/2*		48.3		
6 x 6	168.3	168.3	142.7	142.7
6 x 5		141.3		136.7
6 x 4		114.3		130.0
6 x 3-1/2		101.6		127.0
6 x 3		88.9		124.0
6 x 2-1/2		73.0		120.6
6 x 2*		60.3		
8 x 8	219.1	219.1	177.8	177.8
8 x 6		168.3		168.1
8 x 5		141.3		162.1
8 x 4		114.3		155.4
8 x 3-1/2		101.6		152.4
8 x 3*		88.9		
10 x 10	273.1	273.1	215.9	215.9
10 x 8		219.1		203.2
10 x 6		168.3		193.5
10 x 5		141.3		190.5
10 x 4		114.3		184.2
12 x 12	323.9	323.9	254.0	254.0
12 x 10		273.1		241.3
12 x 8		219.1		228.6
12 x 6		168.3		218.9
12 x 5		141.3		215.9

(1) Outlet dimension "M" for run sizes 14 and larger is recommended but not mandatory.

STAINLESS & CARBON STEEL BUTT-WELDING FITTINGS

WELLGROW INDUSTRIES CORP.

Equal and Reducing Tees

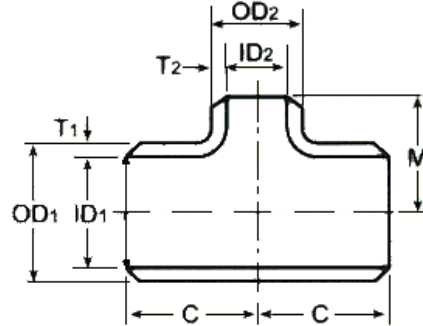
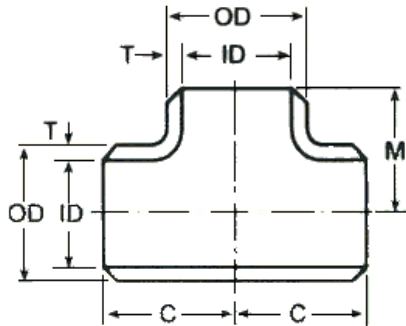

MSS SP-75 ANSI B16.9 (in mm)
* Wellgrow's standard.

Nominal Pipe Size (NPS)	Outside Diameter At Bevel D		Center to End	
	Run	Outlet	Run C	Outlet (1) M
14 x 14	355.6	355.6	279.4	279.4
14 x 12		323.9		269.7
14 x 10		273.1		257.0
14 x 8		219.1		247.6
14 x 6		168.3		238.3
16 x 16	406.4	406.4	304.8	304.8
16 x 14		355.6		304.8
16 x 12		323.9		295.1
16 x 10		273.1		282.4
16 x 8		219.1		373.0
16 x 6		168.3		263.7
18 x 18	457.2	457.2	342.9	342.9
18 x 16		406.4		330.2
18 x 14		355.6		330.2
18 x 12		323.9		320.5
18 x 10		273.1		307.8
18 x 8		219.1		298.4
20 x 20	508.0	508.0	381.0	381.0
20 x 18		457.2		369.3
20 x 16		406.4		355.6
20 x 14		355.6		355.6
20 x 12		323.9		345.9
20 x 10		273.1		333.2
20 x 8		219.1		323.8
22 x 22	558.8	558.8	419.1	419.1
22 x 20		508.0		406.4
22 x 18		457.2		393.7
22 x 16		406.4		381.0
22 x 14		355.6		381.0
22 x 12		323.9		371.3
22 x 10		273.1		358.6
24 x 24	609.6	609.6	431.8	431.8
24 x 22		558.8		431.8
24 x 20		508.0		431.8
24 x 18		457.2		419.1
24 x 16		406.4		406.4
24 x 14		355.6		406.4
24 x 12		323.9		396.7
24 x 10		273.1		384.0
26 x 26	660.4	660.4	495.3	495.3
26 x 24		609.6		482.6

Nominal Pipe Size (NPS)	Outside Diameter At Bevel D		Center to End	
	Run	Outlet	Run C	Outlet (1) M
26 x 22		558.8		469.9
26 x 20		508.0		457.2
26 x 18		457.2		444.5
26 x 16		406.4		431.8
26 x 14		355.6		431.8
26 x 12		323.1		422.1
28 x 28	711.2	711.2	520.7	520.7
28 x 26		660.4		520.7
28 x 24		609.6		508.0
28 x 22		558.8		495.3
28 x 20		508.0		482.6
28 x 18		457.2		469.9
28 x 16		406.4		457.2
28 x 14		355.6		457.2
28 x 12		323.1		447.5
30 x 30	762.0	762.0	558.8	558.8
30 x 28		711.2		546.1
30 x 26		660.4		546.1
30 x 24		609.6		533.4
30 x 22		558.8		520.7
30 x 20		508.0		508.0
30 x 18		457.2		495.3
30 x 16		406.4		482.6
30 x 14		355.6		482.6
30 x 12		323.9		472.6
30 x 10		273.1		460.2
32 x 32	812.8	812.8	596.9	596.9
32 x 30		762.0		584.2
32 x 28		711.2		571.5
32 x 26		660.4		571.5
32 x 24		609.6		558.8
32 x 22		558.8		546.1
32 x 20		508.0		533.4
32 x 18		457.2		520.7
32 x 16		406.4		508.0
32 x 14		355.6		508.0
34 x 34	863.6	863.6	635.0	635.0
34 x 32		812.8		622.3
34 x 30		762.0		609.6
34 x 28		711.2		596.9
34 x 26		660.4		596.9

(1) Outlet dimension "M" for run sizes 14 and larger is recommended but not mandatory.

STAINLESS & CARBON STEEL BUTT-WELDING FITTINGS

WELLGROW INDUSTRIES CORP.

Equal and Reducing Tees

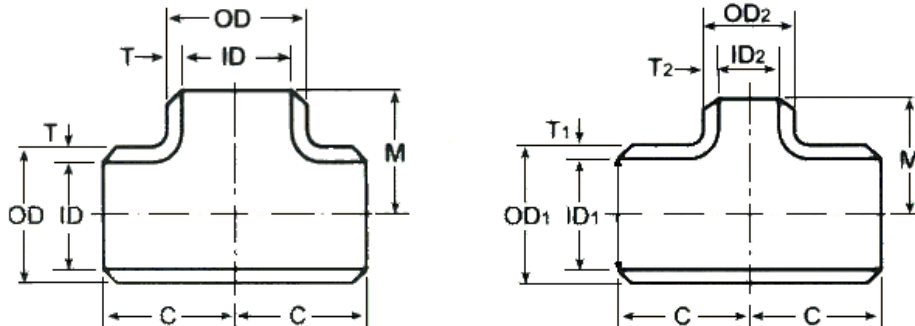

MSS SP-75 ANSI B16.9 (in mm)
* Wellgrow's standard.

Nominal Pipe Size (NPS)	Outside Diameter At Bevel D		Center to End	
	Run	Outlet	Run C	Outlet (1) M
34 x 24		609.6		584.2
34 x 22		558.8		571.5
34 x 20		508.0		558.8
34 x 18		457.2		546.1
34 x 16		406.4		533.4
36 x 36	914.4	914.4	673.1	673.1
36 x 34		863.6		660.4
36 x 32		812.8		647.7
36 x 30		762.0		635.0
36 x 28		711.2		622.3
36 x 26		660.4		622.3
36 x 24		609.6		609.6
36 x 22		558.8		596.9
36 x 20		508.0		584.2
36 x 18		457.2		571.5
36 x 16		406.4		558.8
38 x 38	965.2	965.2	711.2	711.2
38 x 36		914.4		711.2
38 x 34		863.6		698.5
38 x 32		812.8		685.8
38 x 30		762.0		673.1
38 x 28		711.2		647.7
38 x 26		660.4		647.7
38 x 24		609.6		635.0
38 x 22		558.8		622.3
38 x 20		508.0		609.6
38 x 18		457.2		596.9
40 x 40	1016.0	1016.0	749.3	749.3
40 x 38		965.2		749.3
40 x 36		914.4		736.6
40 x 34		863.6		723.9
40 x 32		812.8		711.2
40 x 30		762.0		698.5
40 x 28		711.2		673.1
40 x 26		660.4		673.1
40 x 24		609.6		660.4
40 x 22		558.8		647.7
40 x 20		508.0		635.0
40 x 18		457.2		622.3
42 x 42	1066.8	1066.8	762.0	711.2
42 x 40		1016.0		711.2

Nominal Pipe Size (NPS)	Outside Diameter At Bevel D		Center to End	
	Run	Outlet	Run C	Outlet (1) M
42 x 38		965.2		711.2
42 x 36		914.4		711.2
42 x 34		863.6		711.2
42 x 32		812.8		711.2
42 x 30		762.0		711.2
42 x 28	1066.8	711.2	762.0	698.5
42 x 26		660.4		698.5
42 x 24		609.6		660.4
42 x 22		558.8		660.4
42 x 20		508.0		660.4
42 x 18		457.2		647.7
42 x 16		406.4		635.0
44 x 44	1117.6	1117.6	812.8	762.0
44 x 42		1066.8		762.0
44 x 40		1016.0		749.3
44 x 38		965.2		736.6
44 x 36		914.4		723.9
44 x 34		863.6		723.9
44 x 32		812.8		711.2
44 x 30		762.0		711.2
44 x 28		711.2		698.5
44 x 26		660.4		698.5
44 x 24		609.6		698.5
44 x 22		558.8		685.8
44 x 20		508.0		685.8
46 x 46	1168.4	1168.4	850.9	800.1
46 x 44		1117.6		800.1
46 x 42		1066.8		787.4
46 x 40		1016.0		774.7
46 x 38		965.2		762.0
46 x 36		914.4		762.0
46 x 34		863.6		749.3
46 x 32		812.8		749.3
46 x 30		762.0		736.6
46 x 28		711.2		736.6
46 x 26		660.4		736.6
46 x 24		609.6		723.9
46 x 20*		508.0		723.9
48 x 48	1219.2	1219.2	889.0	838.2
48 x 46		1168.4		838.2
48 x 44		1117.6		838.2

(1) Outlet dimension "M" for run sizes 14 and larger is recommended but not mandatory.

STAINLESS & CARBON STEEL BUTT-WELDING FITTINGS

WELLGROW INDUSTRIES CORP.

Equal and Reducing Tees

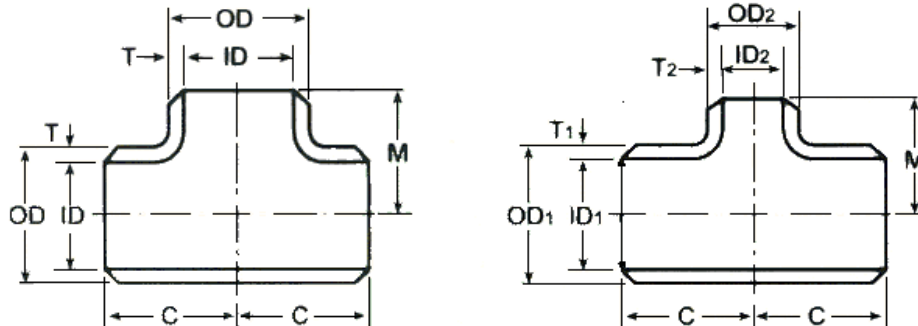

MSS SP-75 ANSI B16.9 (in mm)
* Wellgrow's standard.

Nominal Pipe Size (NPS)	Outside Diameter At Bevel D		Center to End	
	Run	Outlet	Run C	Outlet (1) M
48 x 42		1066.8		812.8
48 x 40		1016.0		812.8
48 x 38		965.2		812.8
48 x 36		914.4		787.4
48 x 34		863.6		787.4
48 x 32	1219.2	812.8	889.0	787.4
48 x 44		1117.6		838.2
48 x 42		1066.8		812.8
48 x 40		1016.0		812.8
48 x 38		965.2		812.8
48 x 36		914.4		787.4
48 x 34		863.6		787.4
48 x 32		812.8		787.4
48 x 30		762.0		762.0
48 x 28		711.2		762.0
48 x 26		660.4		762.0
48 x 24		609.6		736.6
48 x 22		558.8		736.6
52 x 52*	1320.8	1320.8	965.2	914.4
52 x 48*		1219.2		863.6
52 x 44*		1117.6		812.8
52 x 40*		1016.0		762.0
54 x 54*	1371.6	1371.6	1003.3	952.5
54 x 52*		1320.8		914.4
54 x 48*		1219.2		863.6
54 x 44*		1117.6		863.6
54 x 40*		1016.0		812.8
54 x 28*		711.2		787.4
54 x 20*		508.0		787.4
56 x 56*	1422.4	1422.4	1041.4	965.2
56 x 52*		1320.8		914.4
56 x 48*		1219.2		863.6
56 x 44*		1117.6		812.8
56 x 40*		1016.0		812.8
56 x 28*		711.2		812.8
56 x 20*		508.0		812.8
60 x 60*	1524.0	1524.0	1117.6	1016.0
60 x 56*		1422.4		965.2
60 x 52*		1320.8		914.4
60 x 48*		1219.2		863.6

Nominal Pipe Size (NPS)	Outside Diameter At Bevel D		Center to End	
	Run	Outlet	Run C	Outlet (1) M
60 x 40*		1016.0		863.6
60 x 28*		711.2		863.6
60 x 20*		508.0		863.6
64 x 64*	1626.0	1626.0	1194.0	1092.0
64 x 60*		1524.0		1067.0
64 x 56*		1422.0		1016.0
64 x 52*		1321.0		965.0
64 x 48*		1219.0		914
66 x 66*	1676.4	1676.4	1219.2	1066.8
68 x 68*	1727.0	1727.0	1270.0	1168.0
68 x 64*		1626.0		1143.0
68 x 60*		1524.0		1118.0
68 x 56*		1422.0		1067.0
68 x 52*		1321.0		1016.0
68 x 48*		1219.0		965.0
72 x 72*	1829.0	1829.0	1320.0	1245.0
72 x 68*		1727.0		1219.0
72 x 64*		1626.0		1194.0
72 x 60*		1524.0		1168.0
72 x 56*	1829.0	1422.0	1320.0	1118.0
72 x 52*		1321.0		1067.0
72 x 48*		1219.0		1016.0
76 x 76*	1930.0	1930.0	1422.0	1320.0
76 x 72*		1829.0		1295.0
76 x 68*		1727.0		1270.0
76 x 64*		1626.0		1245.0
76 x 60*		1524.0		1219.0
76 x 56*		1422.0		1168.0
76 x 52*		1321.0		1118.0
76 x 48*		1219.0		1067.0
80 x 80*	2032.0	2032.0	1499.0	1397.0
80 x 76*		1930.0		1372.0
80 x 72*		1829.0		1346.0
80 x 68*		1727.0		1321.0
80 x 64*		1626.0		1295.0
80 x 60*		1524.0		1270.0
80 x 56*		1422.0		1219.0
80 x 52*		1321.0		1168.0
80 x 48*		1219.0		1118.0

(1) Outlet dimension "M" for run sizes 14 and larger is recommended but not mandatory.

STAINLESS & CARBON STEEL BUTT-WELDING FITTINGS

WELLGROW INDUSTRIES CORP.

Equal and Reducing Crosses

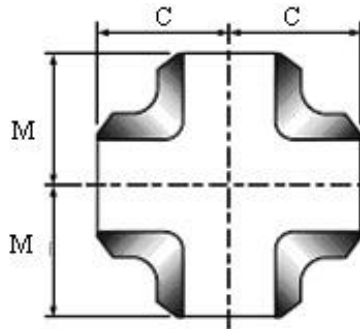

MSS SP-75 ANSI B16.9 (in mm)
* Wellgrow's standard.

Nominal Pipe Size (NPS)	Outside Diameter At Bevel D		Center to End	
	Run	Outlet	Run C	Outlet (1) M
1/2 x 1/2	21.3	21.3	25.4	25.4
1/2 x 3/8		17.1		25.4
1/2 x 1/4		13.7		25.4
3/4 x 3/4	26.7	26.7	28.4	28.4
3/4 x 1/2		21.3		28.4
3/4 x 3/8		17.1		28.4
1 x 1	33.4	33.4	38.1	38.1
1 x 3/4		26.7		38.1
1 x 1/2		21.3		38.1
1-1/4 x 1-1/4	42.2	42.2	47.8	47.8
1-1/4 x 1		33.4		47.8
1-1/4 x 3/4		26.7		47.8
1-1/4 x 1/2		21.3		47.8
1-1/2 x 1-1/2	48.3	48.3	57.2	57.2
1-1/2 x 1-1/4		42.2		57.2
1-1/2 x 1		33.4		57.2
1-1/2 x 3/4		26.7		57.2
1-1/2 x 1/2		21.3		57.2
2 x 2	60.3	60.3	63.5	63.5
2 x 1-1/2		48.3		60.5
2 x 1-1/4		42.2		57.2
2 x 1		33.4		50.8
2 x 3/4		26.7		44.4
2 x 1/2*		21.3		
2-1/2 x 2-1/2	73.0	73.0	76.2	76.2
2-1/2 x 2		60.3		69.8
2-1/2 x 1-1/2		48.3		66.5
2-1/2 x 1-1/4		42.2		63.5
2-1/2 x 1		33.4		57.2
3 x 3	88.9	88.9	85.9	85.9
3 x 2-1/2		73.0		82.6
3 x 2		60.3		76.2
3 x 1-1/2		48.3		73.2
3 x 1-1/4		42.2		69.8
3 x 1*		33.4		
3-1/2 x 3-1/2	101.6	101.6	95.2	95.2
3-1/2 x 3		88.9		91.9
3-1/2 x 2-1/2		73.0		88.9
3-1/2 x 2		60.3		82.6
3-1/2 x 1-1/2		48.3		79.2

Nominal Pipe Size (NPS)	Outside Diameter At Bevel D		Center to End	
	Run	Outlet	Run C	Outlet (1) M
4 x 4	114.3	114.3	104.6	104.6
4 x 3-1/2		101.6		101.6
4 x 3		88.9		98.6
4 x 2-1/2		73.0		95.2
4 x 2		60.3		88.9
4 x 1-1/2		48.3		85.9
4 x 1-1/4		42.2		
4 x 1*		33.5		
5 x 5	141.3	141.3	124.0	124.0
5 x 4		114.3		117.3
5 x 3-1/2		101.6		114.3
5 x 3		88.9		111.3
5 x 2-1/2		73.0		108.0
5 x 2		60.3		104.6
5 x 1-1/2*		48.3		
6 x 6	168.3	168.3	142.7	142.7
6 x 5		141.3		136.7
6 x 4		114.3		130.0
6 x 3-1/2		101.6		127.0
6 x 3		88.9		124.0
6 x 2-1/2		73.0		120.6
6 x 2*		60.3		
8 x 8	219.1	219.1	177.8	177.8
8 x 6		168.3		168.1
8 x 5		141.3		162.1
8 x 4		114.3		155.4
8 x 3-1/2		101.6		152.4
8 x 3*		88.9		
10 x 10	273.1	273.1	215.9	215.9
10 x 8		219.1		203.2
10 x 6		168.3		193.5
10 x 5		141.3		190.5
10 x 4		114.3		184.2
12 x 12	323.9	323.9	254.0	254.0
12 x 10		273.1		241.3
12 x 8		219.1		228.6
12 x 6		168.3		218.9
12 x 5		141.3		215.9

(1) Outlet dimension "M" for run sizes 14 and larger is recommended but not mandatory.

Tel: 886-4-23112576 Fax: 886-4-23112578 E-mail: wellgrow@ms18.hinet.net

STAINLESS & CARBON STEEL BUTT-WELDING FITTINGS

WELLGROW INDUSTRIES CORP.

Equal and Reducing Crosses

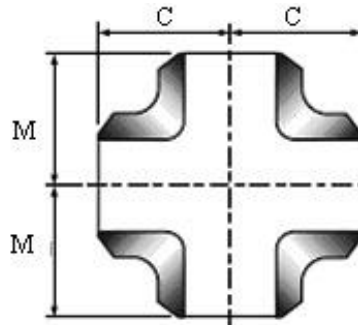

MSS SP-75 ANSI B16.9 (in mm)
* Wellgrow's standard.

Nominal Pipe Size (NPS)	Outside Diameter At Bevel D		Center to End		Nominal Pipe Size (NPS)	Outside Diameter At Bevel D		Center to End	
	Run	Outlet	Run C	Outlet (1) M		Run	Outlet	Run C	Outlet (1) M
14 x 14	355.6	355.6	279.4	279.4	26 x 22		558.8		469.9
14 x 12		323.9		269.7	26 x 20		508.0		457.2
14 x 10		273.1		257.0	26 x 18		457.2		444.5
14 x 8		219.1		247.6	26 x 16		406.4		431.8
14 x 6		168.3		238.3	26 x 14		355.6		431.8
16 x 16	406.4	406.4	304.8	304.8	26 x 12		323.1		422.1
16 x 14		355.6		304.8	28 x 28	711.2	711.2	520.7	520.7
16 x 12		323.9		295.1	28 x 26		660.4		520.7
16 x 10		273.1		282.4	28 x 24		609.6		508.0
16 x 8		219.1		373.0	28 x 22		558.8		495.3
16 x 6		168.3		263.7	28 x 20		508.0		482.6
18 x 18	457.2	457.2	342.9	342.9	28 x 18		457.2		469.9
18 x 16		406.4		330.2	28 x 16		406.4		457.2
18 x 14		355.6		330.2	28 x 14		355.6		457.2
18 x 12		323.9		320.5	28 x 12		323.1		447.5
18 x 10		273.1		307.8	30 x 30	762.0	762.0	558.8	558.8
18 x 8		219.1		298.4	30 x 28		711.2		546.1
20 x 20	508.0	508.0	381.0	381.0	30 x 26		660.4		546.1
20 x 18		457.2		369.3	30 x 24		609.6		533.4
20 x 16		406.4		355.6	30 x 22		558.8		520.7
20 x 14		355.6		355.6	30 x 20		508.0		508.0
20 x 12		323.9		345.9	30 x 18		457.2		495.3
20 x 10		273.1		333.2	30 x 16		406.4		482.6
20 x 8		219.1		323.8	30 x 14		355.6		482.6
22 x 22	558.8	558.8	419.1	419.1	30 x 12		323.9		472.6
22 x 20		508.0		406.4	30 x 10		273.1		460.2
22 x 18		457.2		393.7	32 x 32	812.8	812.8	596.9	596.9
22 x 16		406.4		381.0	32 x 30		762.0		584.2
22 x 14		355.6		381.0	32 x 28		711.2		571.5
22 x 12		323.9		371.3	32 x 26		660.4		571.5
22 x 10		273.1		358.6	32 x 24		609.6		558.8
24 x 24	609.6	609.6	431.8	431.8	32 x 22		558.8		546.1
24 x 22		558.8		431.8	32 x 20		508.0		533.4
24 x 20		508.0		431.8	32 x 18		457.2		520.7
24 x 18		457.2		419.1	32 x 16		406.4		508.0
24 x 16		406.4		406.4	32 x 14		355.6		508.0
24 x 14		355.6		406.4	34 x 34	863.6	863.6	635.0	635.0
24 x 12		323.9		396.7	34 x 32		812.8		622.3
24 x 10		273.1		384.0	34 x 30		762.0		609.6
26 x 26	660.4	660.4	495.3	495.3	34 x 28		711.2		596.9
26 x 24		609.6		482.6	34 x 26		660.4		596.9

(1) Outlet dimension "M" for run sizes 14 and larger is recommended but not mandatory.

STAINLESS & CARBON STEEL BUTT-WELDING FITTINGS

WELLGROW INDUSTRIES CORP.

Equal and Reducing Crosses

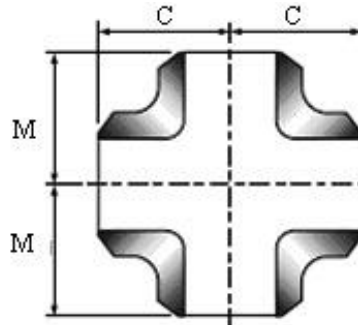

MSS SP-75 ANSI B16.9 (in mm)
* Wellgrow's standard.

Nominal Pipe Size (NPS)	Outside Diameter At Bevel D		Center to End	
	Run	Outlet	Run C	Outlet (1) M
34 x 24		609.6		584.2
34 x 22		558.8		571.5
34 x 20		508.0		558.8
34 x 18		457.2		546.1
34 x 16		406.4		533.4
36 x 36	914.4	914.4	673.1	673.1
36 x 34		863.6		660.4
36 x 32		812.8		647.7
36 x 30		762.0		635.0
36 x 28		711.2		622.3
36 x 26		660.4		622.3
36 x 24		609.6		609.6
36 x 22		558.8		596.9
36 x 20		508.0		584.2
36 x 18		457.2		571.5
36 x 16		406.4		558.8
38 x 38	965.2	965.2	711.2	711.2
38 x 36		914.4		711.2
38 x 34		863.6		698.5
38 x 32		812.8		685.8
38 x 30		762.0		673.1
38 x 28		711.2		647.7
38 x 26		660.4		647.7
38 x 24		609.6		635.0
38 x 22		558.8		622.3
38 x 20		508.0		609.6
38 x 18		457.2		596.9
40 x 40	1016.0	1016.0	749.3	749.3
40 x 38		965.2		749.3
40 x 36		914.4		736.6
40 x 34		863.6		723.9
40 x 32		812.8		711.2
40 x 30		762.0		698.5
40 x 28		711.2		673.1
40 x 26		660.4		673.1
40 x 24		609.6		660.4
40 x 22		558.8		647.7
40 x 20		508.0		635.0
40 x 18		457.2		622.3
42 x 42	1066.8	1066.8	762.0	711.2
42 x 40		1016.0		711.2

Nominal Pipe Size (NPS)	Outside Diameter At Bevel D		Center to End	
	Run	Outlet	Run C	Outlet (1) M
42 x 38		965.2		711.2
42 x 36		914.4		711.2
42 x 34		863.6		711.2
42 x 32		812.8		711.2
42 x 30		762.0		711.2
42 x 28	1066.8	711.2	762.0	698.5
42 x 26		660.4		698.5
42 x 24		609.6		660.4
42 x 22		558.8		660.4
42 x 20		508.0		660.4
42 x 18		457.2		647.7
42 x 16		406.4		635.0
44 x 44	1117.6	1117.6	812.8	762.0
44 x 42		1066.8		762.0
44 x 40		1016.0		749.3
44 x 38		965.2		736.6
44 x 36		914.4		723.9
44 x 34		863.6		723.9
44 x 32		812.8		711.2
44 x 30		762.0		711.2
44 x 28		711.2		698.5
44 x 26		660.4		698.5
44 x 24		609.6		698.5
44 x 22		558.8		685.8
44 x 20		508.0		685.8
46 x 46	1168.4	1168.4	850.9	800.1
46 x 44		1117.6		800.1
46 x 42		1066.8		787.4
46 x 40		1016.0		774.7
46 x 38		965.2		762.0
46 x 36		914.4		762.0
46 x 34		863.6		749.3
46 x 32		812.8		749.3
46 x 30		762.0		736.6
46 x 28		711.2		736.6
46 x 26		660.4		736.6
46 x 24		609.6		723.9
46 x 20*		508.0		723.9
48 x 48	1219.2	1219.2	889.0	838.2
48 x 46		1168.4		838.2
48 x 44		1117.6		838.2

(1) Outlet dimension "M" for run sizes 14 and larger is recommended but not mandatory.

STAINLESS & CARBON STEEL BUTT-WELDING FITTINGS

WELLGROW INDUSTRIES CORP.

Equal and Reducing Crosses

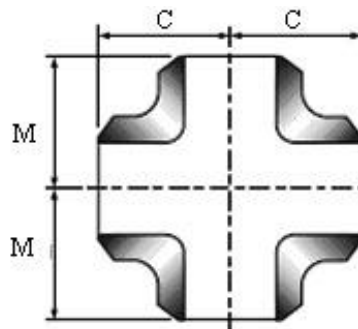

MSS SP-75 ANSI B16.9 (in mm)
* Wellgrow's standard.

Nominal Pipe Size (NPS)	Outside Diameter At Bevel D		Center to End	
	Run	Outlet	Run C	Outlet (1) M
48 x 42		1066.8		812.8
48 x 40		1016.0		812.8
48 x 38		965.2		812.8
48 x 36		914.4		787.4
48 x 34		863.6		787.4
48 x 32	1219.2	812.8	889.0	787.4
48 x 44		1117.6		838.2
48 x 42		1066.8		812.8
48 x 40		1016.0		812.8
48 x 38		965.2		812.8
48 x 36		914.4		787.4
48 x 34		863.6		787.4
48 x 32		812.8		787.4
48 x 30		762.0		762.0
48 x 28		711.2		762.0
48 x 26		660.4		762.0
48 x 24		609.6		736.6
48 x 22		558.8		736.6
52 x 52*	1320.8	1320.8	965.2	914.4
52 x 48*		1219.2		863.6
52 x 44*		1117.6		812.8
52 x 40*		1016.0		762.0
54 x 54*	1371.6	1371.6	1003.3	952.5
54 x 52*		1320.8		914.4
54 x 48*		1219.2		863.6
54 x 44*		1117.6		863.6
54 x 40*		1016.0		812.8
54 x 28*		711.2		787.4
54 x 20*		508.0		787.4
56 x 56*	1422.4	1422.4	1041.4	965.2
56 x 52*		1320.8		914.4
56 x 48*		1219.2		863.6
56 x 44*		1117.6		812.8
56 x 40*		1016.0		812.8
56 x 28*		711.2		812.8
56 x 20*		508.0		812.8
60 x 60*	1524.0	1524.0	1117.6	1016.0
60 x 56*		1422.4		965.2
60 x 52*		1320.8		914.4
60 x 48*		1219.2		863.6

Nominal Pipe Size (NPS)	Outside Diameter At Bevel D		Center to End	
	Run	Outlet	Run C	Outlet (1) M
60 x 40*		1016.0		863.6
60 x 28*		711.2		863.6
60 x 20*		508.0		863.6
64 x 64*	1626.0	1626.0	1194.0	1092.0
64 x 60*		1524.0		1067.0
64 x 56*		1422.0		1016.0
64 x 52*		1321.0		965.0
64 x 48*		1219.0		914
66 x 66*	1676.4	1676.4	1219.2	1066.8
68 x 68*	1727.0	1727.0	1270.0	1168.0
68 x 64*		1626.0		1143.0
68 x 60*		1524.0		1118.0
68 x 56*		1422.0		1067.0
68 x 52*		1321.0		1016.0
68 x 48*		1219.0		965.0
72 x 72*	1829.0	1829.0	1320.0	1245.0
72 x 68*		1727.0		1219.0
72 x 64*		1626.0		1194.0
72 x 60*		1524.0		1168.0
72 x 56*	1829.0	1422.0	1320.0	1118.0
72 x 52*		1321.0		1067.0
72 x 48*		1219.0		1016.0
76 x 76*	1930.0	1930.0	1422.0	1320.0
76 x 72*		1829.0		1295.0
76 x 68*		1727.0		1270.0
76 x 64*		1626.0		1245.0
76 x 60*		1524.0		1219.0
76 x 56*		1422.0		1168.0
76 x 52*		1321.0		1118.0
76 x 48*		1219.0		1067.0
80 x 80*	2032.0	2032.0	1499.0	1397.0
80 x 76*		1930.0		1372.0
80 x 72*		1829.0		1346.0
80 x 68*		1727.0		1321.0
80 x 64*		1626.0		1295.0
80 x 60*		1524.0		1270.0
80 x 56*		1422.0		1219.0
80 x 52*		1321.0		1168.0
80 x 48*		1219.0		1118.0

(1) Outlet dimension "M" for run sizes 14 and larger is recommended but not mandatory.

STAINLESS & CARBON STEEL BUTT-WELDING FITTINGS

WELLGROW INDUSTRIES CORP.

Concentric and Eccentric Reducers

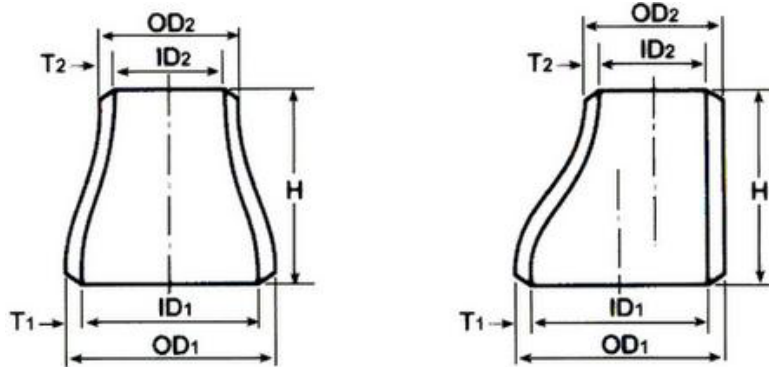

MSS SP-75 ANSI B16.9 (in mm)
* Wellgrow's standard.

Nominal Pipe Size (NPS)	Outside Diameter at Bevel		End-to-end
	Large End	Small End	
3/4 x 1/2	26.7	21.3	38.1
3/4 x 3/8		17.3	
1 x 3/4	33.4	26.7	50.8
1 x 1/2		21.3	
1-1/4 x 1	42.2	33.4	50.8
1-1/4 x 3/4		26.7	
1-1/4 x 1/2		21.3	
1-1/2 x 1-1/4	48.3	42.2	63.5
1-1/2 x 1		33.4	
1-1/2 x 3/4		26.7	
1-1/2 x 1/2		21.3	
2 x 1-1/2	60.3	48.3	76.2
2 x 1-1/4		42.2	
2 x 1		33.4	
2 x 3/4		26.7	
2-1/2 x 2	73.0	60.3	88.9
2-1/2 x 1-1/2		48.3	
2-1/2 x 1-1/4		42.2	
2-1/2 x 1		33.4	
3 x 2-1/2	88.9	73.0	88.9
3 x 2		60.3	
3 x 1-1/2		48.3	
3 x 1-1/4		42.2	
3-1/2 x 3	101.6	88.9	101.6
3-1/2 x 2-1/2		73.0	
3-1/2 x 2		60.3	
3-1/2 x 1-1/2		48.3	
3-1/2 x 1-1/4		42.2	
4 x 3-1/2	114.3	101.6	101.6
4 x 3		88.9	
4 x 2-1/2		73.0	
4 x 2		60.3	
4 x 1-1/2		48.3	
5 x 4	141.3	114.3	127.0
5 x 3-1/2		101.6	
5 x 3		88.9	
5 x 2-1/2		73.0	
5 x 2		60.3	
6 x 5	168.3	141.3	139.7
6 x 4		114.3	
6 x 3-1/2		101.6	
6 x 3		88.9	
6 x 2-1/2		73.0	

Nominal Pipe Size (NPS)	Outside Diameter at Bevel		End-to-end
	Large End	Small End	
8 x 6	219.1	168.3	152.4
8 x 5		141.3	
8 x 4		114.3	
8 x 3-1/2		101.6	
8 x 3		88.9	
8 x 2-1/2		73.0	
10 x 8	273.1	29.1	177.8
10 x 6		168.3	
10 x 5		141.3	
10 x 4		114.3	
12 x 10	323.9	273.1	203.2
12 x 8		219.1	
12 x 6		168.3	
12 x 5		141.3	
14 x 12	355.6	323.9	330.2
14 x 10		273.1	
14 x 8		219.1	
14 x 6		168.3	
16 x 14	406.4	355.6	355.6
16 x 12		323.9	
16 x 10		273.1	
16 x 8		219.1	
18 x 16	457.2	406.4	381.0
18 x 14		355.6	
18 x 12		323.9	
18 x 10		273.1	
18 x 8		219.1	
20 x 18	508.0	457.2	508.0
20 x 16		406.4	
20 x 14		355.6	
20 x 12		323.9	
20 x 10		273.0	
22 x 20	558.8	508.0	508.0
22 x 18		457.2	
22 x 16		406.4	
22 x 14		355.6	
22 x 12		323.8	
24 x 22	609.6	558.8	508.0
24 x 20		508.0	
24 x 18		457.2	
24 x 16		406.4	
24 x 16		355.6	
24 x 16		323.8	

STAINLESS & CARBON STEEL BUTT-WELDING FITTINGS

WELLGROW INDUSTRIES CORP.

Concentric and Eccentric Reducers

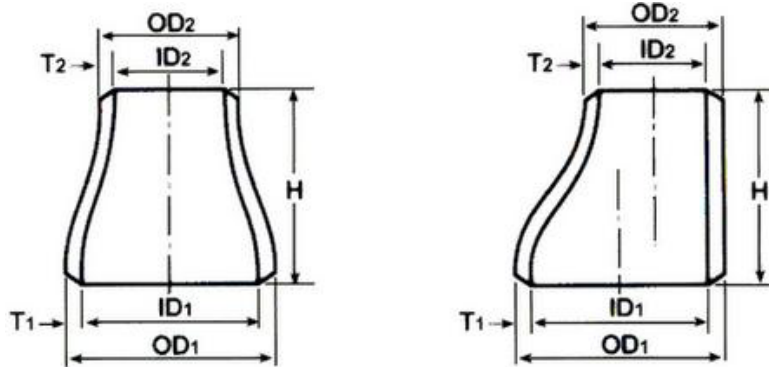

MSS SP-75 ANSI B16.9 (in mm)
* Wellgrow's standard.

Nominal Pipe Size (NPS)	Outside Diameter at Bevel		End-to-end
	Large End	Small End	
26 x 24	660.4	609.6	609.6
26 x 22		558.8	
26 x 20		508.0	
26 x 18		457.2	
26 x 16		406.4	
26 x 14		355.6	
28 x 26	711.2	660.4	609.6
28 x 24		609.6	
28 x 22		559.0	
28 x 20		508.0	
28 x 18		457.2	
28 x 16		406.4	
28 x 14		355.6	
30 x 28	762.0	711.2	609.6
30 x 26		660.4	
30 x 24		609.6	
30 x 22		559.0	
30 x 20		508.0	
30 x 18		457.0	
30 x 16		406.4	
30 x 14		355.6	
32 x 30	813.0	762.0	609.6
32 x 28		711.0	
32 x 26		660.0	
32 x 24		610.0	
32 x 22		559.0	
32 x 20		508.0	
34 x 32	863.6	812.8	609.6
34 x 30		762.0	
34 x 28		711.0	
34 x 26		711.2	
34 x 24		660.4	
34 x 22		559.0	
36 x 34	914.0	864.0	609.6
36 x 32		813.0	
36 x 30		762.0	
36 x 28		711.0	
36 x 26		660.0	
36 x 24		610.0	
36 x 22		559.0	
38 x 36	965.0	914.0	609.6
38 x 34		864.0	
38 x 32		813.0	
38 x 30		762.0	
38 x 28		711.0	
38 x 26		660.0	
38 x 24		610.0	

Nominal Pipe Size (NPS)	Outside Diameter at Bevel		End-to-end
	Large End	Small End	
40 x 38	1016.0	965.0	609.6
40 x 36		914.0	
40 x 34		864.0	
40 x 32		813.0	
40 x 30		762.0	
40 x 28		711.0	
42 x 40	1067.0	1016.0	609.6
42 x 38		965.0	
42 x 36		914.4	
42 x 34		863.6	
42 x 32		812.8	
42 x 30		762.0	
42 x 28		711.0	
44 x 42	1117.6	1066.8	609.6
44 x 40		1016.0	
44 x 38		965.2	
44 x 36		914.4	
44 x 34		864.0	
44 x 32		813.0	
46 x 44	1168.4	1117.6	711.2
46 x 42		1066.8	
46 x 40		1016.0	
46 x 38		965.2	
46 x 36		914.0	
46 x 34		864.0	
48 x 46	1219.2	1168.4	711.2
48 x 44		1117.6	
48 x 42		1066.8	
48 x 40		1016.0	
48 x 38		965.0	
48 x 36		914.0	
52 x 48	1321.0	1219.0	711.2
52 x 46		1168.0	
52 x 44		1118.0	
52 x 42		1067.0	
52 x 40		1016.0	
56 x 52	1422.0	1321.0	711.2
56 x 48		1219.0	
56 x 44		1118.0	
52 x 40		1016.0	
60 x 56	1524.0	1422.0	711.2
60 x 52		1321.0	
60 x 48		1219.0	
60 x 44		1118.0	

STAINLESS & CARBON STEEL BUTT-WELDING FITTINGS

WELLGROW INDUSTRIES CORP.

Pipe Caps

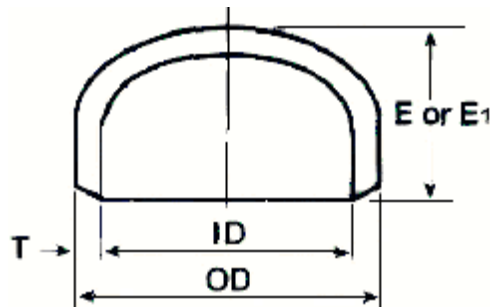

MSS SP-75 ANSI B16.9 (in mm)

Nominal Pipe Size (NPS)	Outside Diameter at Bevel D	Length (2) E	Limiting Wall Thickness for Length E	Length (3) E1
1/2	21.3	25.4	4.6	25.4
3/4	26.7	25.4	3.8	25.4
1	33.4	38.1	4.6	38.1
1-1/4	42.2	38.1	4.8	38.1
1-1/2	48.3	38.1	5.1	38.1
2	60.3	38.1	5.6	44.4
2-1/2	73.0	38.1	7.1	50.8
3	88.9	50.8	7.6	63.5
3-1/2	101.6	63.5	8.1	76.2
4	114.3	63.5	8.6	76.2
5	141.3	76.2	9.7	88.9
6	168.3	88.9	10.9	101.6
8	219.1	101.6	12.7	127.0
10	273.1	127.0	12.7	152.4
12	323.9	152.4	12.7	177.8
14	355.6	165.1	12.7	190.5
16	406.4	177.8	12.7	203.2
18	457.2	203.2	12.7	228.6
20	508.0	228.6	12.7	254.0
22	558.8	254.0	12.7	254.0
24	609.6	266.7	12.7	304.8
26	660.4	266.7		
28	711.2	266.7		
30	762.0	266.7		
32	812.8	266.7		
34	863.6	266.7		
36	914.4	266.7		
38	965.2	304.8		
40	1016.0	304.8		
42	1066.8	304.8		
44	1117.6	342.9		
46	1168.4	342.9		
48	1219.2	342.9		

Wall thickness for caps up to and including 36" conform to ANSI B36.10 specifications. Caps 38" and larger conform to XS specifications for wall thickness of 36". These are Wellgrow's standards as no internationally recognized standards have been set for such large size wall thickness.

- (1) The shape of these caps shall be ellipsoidal and shall conform to the shape requirements as given in the ASME boiler and pressure vessel code.
- (2) Length E applies for thickness not exceeding that given in column "limiting wall thickness for length E".
- (3) Length E1 applies for thickness greater than that given in column "limiting wall thickness" for NPS 24 and smaller. For NPS 26 and larger, length E1 shall be by agreement between manufacturer and purchaser.

STAINLESS & CARBON STEEL BUTT-WELDING FITTINGS

WELLGROW INDUSTRIES CORP.

Stub Ends

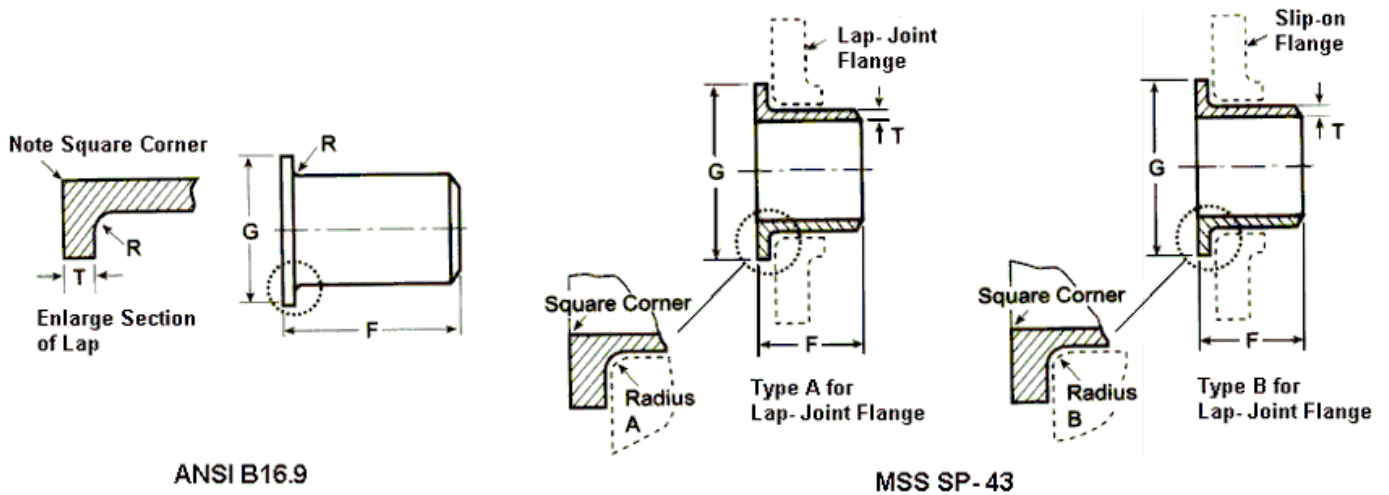

MSS SP-43 ANSI B16.9 (in mm)

Nominal Pipe Size (NPS)	Outside Diameter at Bevel	Outside Diameter of Barrel		Length F		Radius of Fillet R		Diameter of Lap G
		Min.	Max.	ANSI	MSS	ANSI & MSS Type A	MSS Type B	
1/2	21.3	20.55	22.76	76.2	50.8	3.0	0.8	35.0
3/4	26.7	25.88	28.09	76.2	50.8	3.0	0.8	42.9
1	33.4	32.61	34.95	101.6	50.8	3.0	0.8	50.8
1-1/4	42.2	41.38	43.59	101.6	50.8	4.8	0.8	63.5
1-1/2	48.3	47.47	49.94	101.6	50.8	6.4	0.8	73.2
2	60.3	59.54	62.38	152.4	63.5	7.9	0.8	91.9
2-1/2	73.0	72.24	75.34	152.4	63.5	7.9	0.8	104.6
3	88.9	88.11	91.34	152.4	63.5	9.7	0.8	127.0
3-1/2	101.6	100.81	104.04	152.4	76.2	9.7	0.8	139.7
4	114.3	113.51	116.66	152.4	76.2	11.2	0.8	157.2
5	141.3	140.51	144.35	203.2	76.2	11.2	1.5	185.7
6	168.3	167.49	171.27	203.2	88.9	12.7	1.5	215.9
8	219.1	218.29	222.07	203.2	101.6	12.7	1.5	269.7
10	273.1	272.26	277.19	254.0	127.0	12.7	1.5	323.9
12	323.9	323.06	327.99	254.0	152.4	12.7	1.5	381.0
14	355.6	354.81	359.92	304.8	152.4	12.7	1.5	412.8
16	406.4	405.61	410.97	304.8	152.4	12.7	1.5	469.9
18	457.2	456.41	462.03	304.8	152.4	12.7	1.5	533.4
20	508.0	507.21	514.10	304.8	152.4	12.7	1.5	584.2
22	558.8	558.01	564.90	304.8	152.4	12.7	1.5	641.4
24	609.6	608.81	615.70	304.8	152.4	12.7	1.5	692.2

STAINLESS & CARBON STEEL BUTT-WELDING FITTINGS

WELLGROW INDUSTRIES CORP.

Wall Thickness Schedule

JIS G3448 JIS G3455 ANSI B36.10M
JIS G3454 JIS G3459 ANSI B36.19M (in mm)

Nominal Pipe Size		Outside Diameter		Nominal Wall Thickness																		
A	B	JIS	ANSI	Sch 5S	Sch 10S	Sch 20S	GS	Sch 10	LG (7.9)	Sch 20	Sch 30	STD	Sch 40	Sch 60	XS	Sch 80	Sch 100	Sch 120	Sch 140	Sch 160	XXS	
8	1/4	13.8	13.7	1.2	1.65	2.0	2.3	-	-	-	-	(2.2)	2.2	2.4	(3.0)	3.0	-	-	-	-	-	
10	3/8	17.3	17.1	1.2	1.65	2.0	2.3	-	-	-	-	(2.3)	2.3	2.8	(3.2)	3.2	-	-	-	-	-	
15	1/2	21.7	21.3	1.65	2.1	2.5	2.8	-	-	-	-	(2.8)	2.8	3.2	(3.7)	3.7	-	-	-	-	4.7	7.5
20	3/4	27.2	26.7	1.65	2.1	2.5	2.8	-	-	-	-	(2.9)	2.9	3.4	(3.9)	3.9	-	-	-	-	5.5	7.8
25	1	34.0	33.4	1.65	2.8	3.0	3.2	-	-	-	-	(3.4)	3.4	3.9	(4.5)	4.5	-	-	-	-	6.4	9.1
32	1-1/4	42.7	42.2	1.65	2.8	3.0	3.5	-	-	-	-	(3.6)	3.6	4.5	(4.9)	4.9	-	-	-	-	6.4	9.7
40	1-1/2	48.6	48.3	1.65	2.8	3.0	3.5	-	-	-	-	(3.7)	3.7	4.5	(5.1)	5.1	-	-	-	-	7.1	10.2
50	2	60.5	60.3	1.65	2.8	3.5	3.8	-	-	-	-	(3.9)	3.9	4.9	(5.5)	5.5	-	-	-	-	8.7	11.1
65	2-1/2	76.3	73.0	2.1	3.0	3.5	4.2	-	-	-	-	(5.2)	5.2	6.0	(7.0)	7.0	-	-	-	-	9.5	14.0
80	3	89.1	88.9	2.1	3.0	4.0	4.2	-	-	-	-	(5.5)	5.5	6.6	(7.6)	7.6	-	-	-	-	11.1	15.2
90	3-1/2	101.6	101.6	2.1	3.0	4.0	4.2	-	-	-	-	(5.7)	5.7	7.0	(8.1)	8.1	-	-	-	-	12.7	-
100	4	114.3	114.3	2.1	3.0	4.0	4.5	-	-	-	-	(6.0)	6.0	7.1	(8.6)	8.6	-	11.1	-	-	13.5	17.1
125	5	139.8	141.3	2.8	3.4	5.0	4.5	-	-	-	-	(6.6)	6.6	8.1	(9.5)	9.5	-	12.7	-	-	15.9	19.0
150	6	165.2	168.3	2.8	3.4	5.0	5.0	-	5.0**	-	-	(7.1)	7.1	9.3	(11.0)	11.0	-	14.3	-	-	18.2	21.9
175	7	190.7	-	-	-	-	5.3	-	-	-	-	-	-	-	-	-	-	-	-	-	-	-
200	8	216.3	219.1	2.8	3.8	6.5	5.8	-	5.8**	6.4	7.0	(8.2)	8.2	10.3	(12.7)	12.7	15.1	18.2	20.6	23.0	22.2	-
225	9	241.8	-	-	-	-	6.2	-	-	-	-	-	-	-	-	-	-	-	-	-	-	-
250	10	267.4	273.1	3.4	4.2	6.5	6.6	-	6.6**	6.4	7.8	(9.3)	9.3	12.7	12.7	15.1	18.3	21.4	25.4	28.6	25.4	-
300	12	318.5	323.9	4.0	4.6	6.5	6.9	-	6.9**	6.4	8.4	9.5	10.3	14.3	12.7	17.4	21.4	25.4	28.6	33.3	25.4	-
350	14	355.6	355.6	4.0	4.8	7.9	7.9	6.4	7.9	7.9	9.5	9.5	11.1	15.1	12.7	19.0	23.8	27.8	31.8	35.7	-	-
400	16	406.4	406.4	4.2	4.8	7.9	7.9	6.4	7.9	7.9	9.5	9.5	12.7	16.7	12.7	21.4	26.2	30.9	36.5	40.5	-	-
450	18	457.2	457.2	4.2	4.8	7.9	7.9	6.4	7.9	7.9	11.1	9.5	14.3	19.0	12.7	23.8	29.4	34.9	39.7	45.2	-	-
500	20	508.0	508.0	4.8	5.5	7.9	7.9	6.4	7.9	9.5	12.7	9.5	15.1	20.6	12.7	26.2	32.5	38.1	44.4	50.0	-	-
550	22	558.8	558.8	4.8	5.5	-	-	6.4	7.9	9.5	12.7	9.5	-	22.2	12.7	28.6	34.9	41.3	47.6	54.0	-	-
600	24	609.6	609.6	5.5	6.4	-	-	6.4	7.9	9.5	14.3	9.5	17.5	24.6	12.7	31.0	38.9	46.0	52.4	59.5	-	-
650	26	660.4	660.4	-	-	-	-	7.9	7.9	12.7	-	9.5	-	-	12.7	-	-	-	-	-	-	-
700	28	711.2	711.2	-	-	-	-	7.9	7.9	12.7	15.9	9.5	-	-	12.7	-	-	-	-	-	-	-
750	30	762.0	762.0	6.4	7.9	-	-	7.9	7.9	12.7	15.9	9.5	-	-	12.7	-	-	-	-	-	-	-
800	32	812.8	812.8	-	-	-	-	7.9	7.9	12.7	15.9	9.5	17.5	-	12.7	-	-	-	-	-	-	-
850	34	863.6	863.6	-	-	-	-	7.9	7.9	12.7	15.9	9.5	17.5	-	12.7	-	-	-	-	-	-	-
900	36	914.4	914.4	-	-	-	-	7.9	7.9	12.7	15.9	9.5	19.1	-	12.7	-	-	-	-	-	-	-
950	38	965.2	965.2	-	-	-	-	7.9	12.7	-	-	9.5	-	-	12.7	-	-	-	-	-	-	-
1000	40	1016.0	1016.0	-	-	-	-	7.9	-	-	-	9.5	-	-	12.7	-	-	-	-	-	-	-
1050	42	1066.8	1066.8	-	-	-	-	7.9	-	-	-	9.5	-	-	12.7	-	-	-	-	-	-	-
1100	44	1117.6	1117.6	-	-	-	-	7.9	-	-	-	9.5	-	-	12.7	-	-	-	-	-	-	-
1150	46	1168.4	1168.4	-	-	-	-	7.9	-	-	-	9.5	-	-	12.7	-	-	-	-	-	-	-
1200	48	1219.2	1219.2	-	-	-	-	7.9	-	-	-	9.5	-	-	12.7	-	-	-	-	-	-	-
1250	50	1270.0	1270.0	-	-	-	-	7.9	-	-	-	9.5	-	-	12.7	-	-	-	-	-	-	-
1300	52	1320.8	1320.8	-	-	-	-	7.9	-	-	-	9.5	-	-	12.7	-	-	-	-	-	-	-
1350	54	1371.6	1371.6	-	-	-	-	7.9	-	-	-	9.5	-	-	12.7	-	-	-	-	-	-	-
1400	56	1422.4	1422.4	-	-	-	-	7.9	-	-	-	9.5	-	-	12.7	-	-	-	-	-	-	-
1450	58	1473.2	1473.2	-	-	-	-	7.9	-	-	-	9.5	-	-	12.7	-	-	-	-	-	-	-
1500	60	1524.0	1524.0	-	-	-	-	7.9	-	-	-	9.5	-	-	12.7	-	-	-	-	-	-	-
1600	64	1626.0																				
1700	68	1727.0																				
1800	72	1829.0																				
1900	76	1932.0																				
2000	80	2032.0																				

- (1) * Wellgrow's standard.
- (2) **Applied only small end side of the tee and reducers.
- (3) The numerical values in parenthesis are the same thickness as Sch. 40 or Sch. 80.

STAINLESS & CARBON STEEL BUTT-WELDING FITTINGS

WELLGROW INDUSTRIES CORP.

ANSI Dimensional Tolerances

ANSI B16.9, B16.28 (in mm)
* Wellgrow's standard

Nominal Pipe Size	All Fittings			90° and 45° Elbows	Tees	Reducers	Caps	180° Returns		
	Outside Diameter at Bevel OD	Inside Diameter at End ID	Wall Thickness T	Center-to-end Dimension A, B	Center-to-end Dimension C, M	Overall Length H	Overall Length E	Center-to-center Dimension P	Back-to-face Dimension K	Alignment of Ends U
			Not less than 87.5% of nominal thickness							
1/2-2-1/2	+1.5 -0.7	±0.7		±1.5	±1.5	±1.5	±3.0	±6.3	±6.3	±0.7
3-4	±1.5	±1.5								
5-8	+2.2 -1.5						±6.3			
10-18	+4.0 -3.0	±3.0		±2.2	±2.2	±2.2	±6.3	±9.6		±0.7
20-24	+6.3 -4.8	±4.8		±3.0	±3.0	±4.8	±9.6			
26-30				±4.8	±4.8					
32-48										
*50-60	+9.5 -6.4	±6.4		±9.5	±9.5	±9.5		-	-	-
*62-70	+12.7 -9.5	±9.5		±12.7						
*72-80	+15.9 -11.9	±11.9		±15.9						

Nominal Pipe Size	Angularity Tolerance	
	Off Angle Q	Off Plane P
1/2-4	0.7	1.5
5-8	1.5	3.0
10-12	2.2	4.8
14-16		6.3
18-24	3.0	9.6
26-30	4.8	
32-42		19.0
44-48		
*50-60	6.4	
*62-70	9.5	
*72-80	11.9	

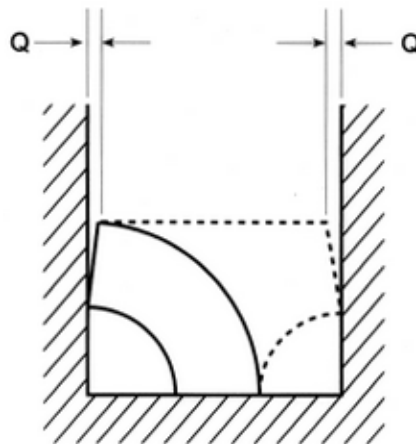

Off Angle

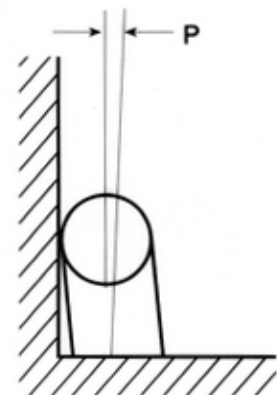

Off Plane

STAINLESS & CARBON STEEL BUTT-WELDING FITTINGS

WELLGROW INDUSTRIES CORP.

MSS Dimensional Tolerances

MSS SP-43 (in mm)

Nominal Pipe Size	All Fittings		90° Elbows 45° Elbows Tees	Reducers Lap Joint Stub Ends	Caps	180° Returns			Lap Joint Stub Ends	
	Outside (1) Diameter at Welding End	Wall Thickness	Center-to-end Dimension	Overall Length	Overall Length	Center-to-center Dimension	Back-to-face Dimension	Alignment of Ends	Fillet (2) Radius of Lap A	Outside Diameter of Lap G
			A, B, C, M	F, H	E	O	K	U		
1/2~1-1/2	±0.8	Not less than 87.5% of nominal thickness	±1.6	±1.6	±3.0	±6.4	±6.4	±0.8	+0 -0.8	+0 -0.8
2~3-1/2	±0.8		±1.6	±1.6	±3.0	±6.4	±6.4	±0.8	+0 -0.8	+0 -0.8
4	±0.8		±1.6	±1.6	±3.0	±6.4	±6.4	±0.8	+0 -1.6	+0 -0.8
5~8	+1.6 -0.8		±1.6	±1.6	±6.4	±6.4	±6.4	±0.8	+0 -1.6	+0 -0.8
10~18	+2.3 -0.8		±2.3	±2.3	±6.4	±9.7	±6.4	±1.6	+0 -1.6	+0 -1.6
20~24	+3.0 -0.8		±2.3	±2.3	±6.4	±9.7	±6.4	±1.6	+0 -1.6	+0 -1.6

- (1) Out of roundness is the vector sum of the plus and minus tolerance.
 (2) Fillet B radius is the maximum.

MSS Dimensional Tolerances

MSS SP-75 (in mm)

Nominal Pipe Size	Inside (1) Diameter at End	Minimum (3) Wall Thickness	Out-of-roundness (2)			90°, 60°, 45°, 30° Elbows & Tees Center-to-end Dimension A, B, C, M		Reducers Overall Length H	Caps Overall Length E	Angularity Off Angle Q	Elbows Off Plane P	Eccentric and Concentric Reducers Off Plane P (6)
			At Ends of fittings		Throughout (4) Body of Elbows	Center-to-end Dimension A, B, C, M						
			Elbows (5)	Other		1-1/2R & Tee	3R					
16~24	±2.3	Nominal	4.8	3.0	2.5%	±2.3	±3.0	±2.3	±6.4	1.5	6.4	2.5%
26~36	±2.3	-0.25	(5)	3.0	2.5%	±3.0	±6.4	±4.8	±9.6	2.3	12.7	2.5%
38~48	±3.0		(5)	3.0	2.5%	±4.8	±9.6	±9.6	±9.6	3.0	19.1	2.5%

- (1) The inside diameter at end shall be determined by circumferential measurement, and the tolerance refers to variations from nominal I.D. calculation by $(OD \text{ nom}^{-24} \text{ nom})$.
 (2) Out-of-roundness tolerances shall be the difference between the maximum and minimum diameters measured on any radial cross-section.
 (3) Minus 0.01 in. except that isolated non-continuous reductions are permitted in accordance with subsection 13.2.1. Excess thickness whether on inside or outside is to be treated in accordance with sketch given in figure 3.
 (4) When elbows are intended for field segmenting, out-of-roundness tolerance may be furnished to 1% by agreement between the manufacturer and the purchaser. It is recognized that extra thickness, if any, may be on the I.D.
 (5) Out-of-roundness tolerances at ends shall be 1% of diameter for NPS 26 and larger.
 (6) Percent of O.D.

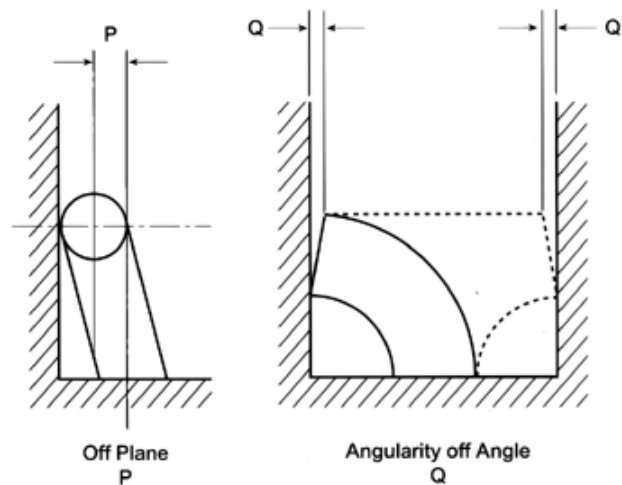

Outside diameter may be tapered at angle up to 30° beyond weld level.

STAINLESS & CARBON STEEL BUTT-WELDING FITTINGS

WELLGROW INDUSTRIES CORP.

Weld End Preparation

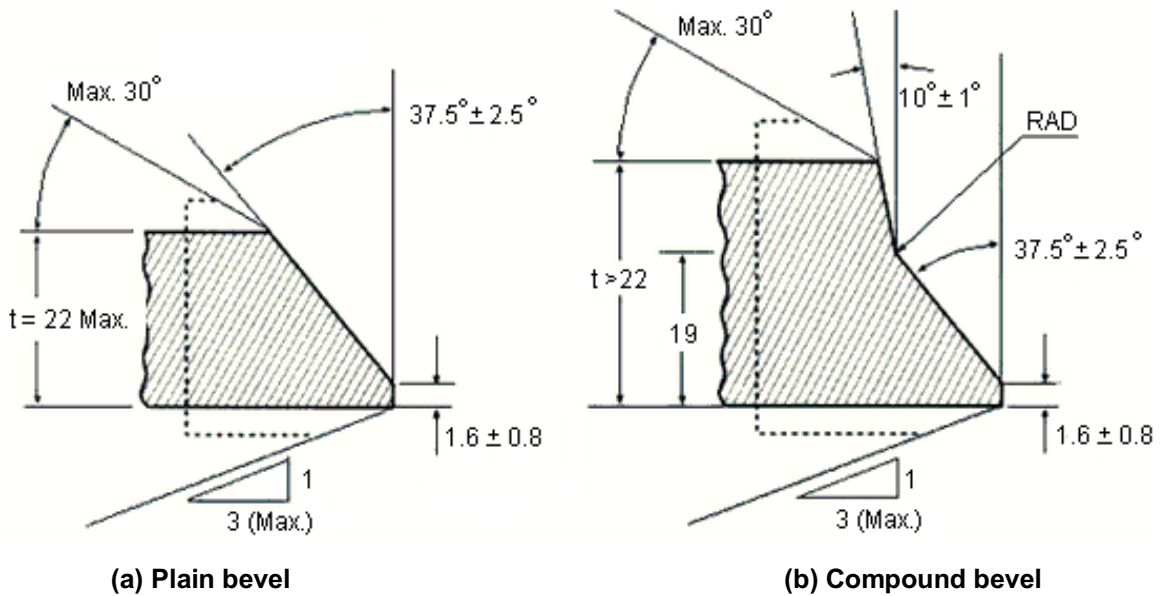

Nominal Pipe Wall Thickness (t)	End Preparation
Less than x*	Cut square or slightly chamfer, at manufacturer's option
X* to 22 included	Plain bevel as in sketch "a" above
More than 22	Compound bevel as in sketch "b" above

X* = 5 for carbon steel, ferritic alloy steel or wrought iron;
4 for austenitic alloy steel

(in mm)

Notes:

- (1) End preparations are in accordance with ANSI B16.25 Paragraph 4.2.
- (2) End preparations conforming to customer specifications will be specially manufactured upon consultation.

MSS SP-75, API 5L

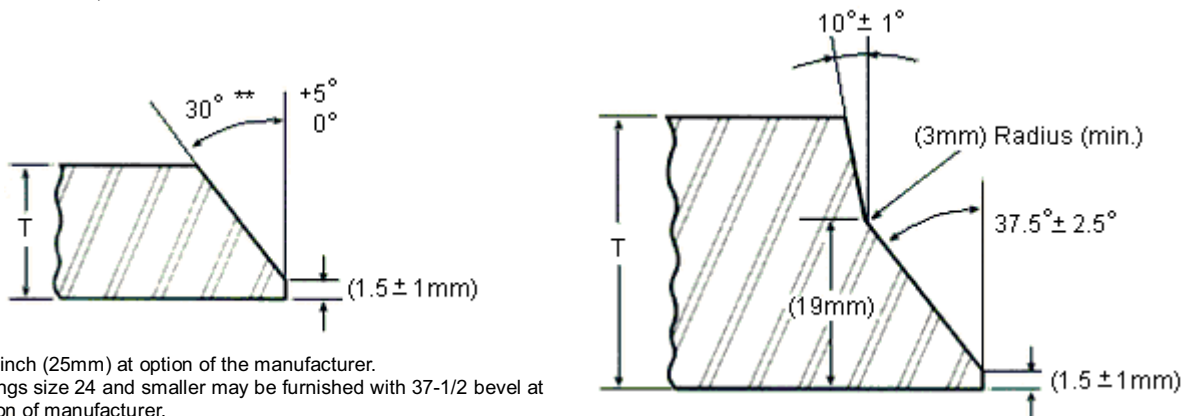

* Or 1 inch (25mm) at option of the manufacturer.

** Fittings size 24 and smaller may be furnished with 37-1/2 bevel at option of manufacturer.

Recommended bevel for wall thickness (T) at end of fitting, 19mm* or less.

Recommended bevel for wall thickness (T) at end of fitting, greater than 19mm.