

EN 1092-1 FLANGES

WELLGROW INDUSTRIES CORP.



- ▲ **Plate Flange**
 - ▲ **Loose Plate Flange With Weld-on Plate Collar**
 - ▲ **Loose Plate Flange With Weld-Neck Collar**
 - ▲ **Blind Flange**
 - ▲ **Weld-Neck Flange**
 - ▲ **Hubbed Slip-On Flange**
 - ▲ **Hubbed Threaded Flange**
 - ▲ **Integral Flange**
 - ▲ **Lapped Pipe Ends**

EN 1092-1 Flanges Summary Chart

Description		Rated Pressure (in bar) (1 bar = 14.5 psi = 100 kPa)										
		6	10	16	25	40	63	100	160	250	320	400
01	Plate flanges for welding	V	V	V	V	V	V	V				
02	Loose plate flanges with weld-on plate collar	V	V	V	V	V						
04	Loose plate flanges with weld-neck collar	V	V	V	V	V						
05	Blank <blind> flanges	V	V	V	V	V	V					
11	Weld-Neck Flanges	V	V	V	V	V	V	V	V	V	V	V
12	Hubbed slip-on flanges for welding	V	V	V	V	V	V					
13	Hubbed threaded flanges			V		V	V	V				
21	Integral flanges	V	V	V	V	V	V	V	V	V	V	V
32	Weld-on plate collars	V	V	V	V	V						
33	Lapped pipe ends	V	V	V	V	V						
34	Weld-neck collars	V	V	V	V	V						

Flange Facing Type EN 1092-1

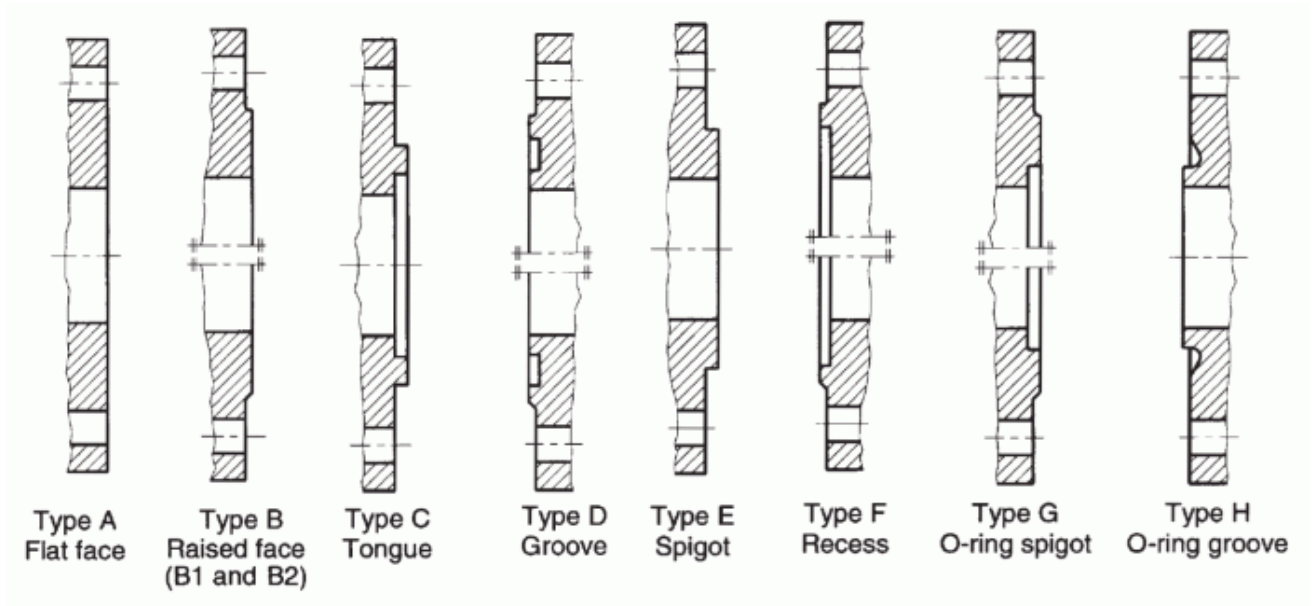

Note 1: For facings types B, D, F and G, the transition from the edge of the raised face to the flange shall be radius, or chamfer at the choice of the flange manufacturer.

Note 2: B1 and B2 are raised face (type B) for different applications.

For flanges and collars (except types 33, 36 and 37) with facing types A, B1, E and F, turning shall be carried out with a round nosed tool in accordance with Table as hereunder.

Surface finish for jointing faces

Facing types	Method of machining	Radius of tool nose mm	Ra ^a µm		Rz ^a µm	
			Min.	Max.	Min.	Max.
A, B1 ^b , E, F	Turning ^c	1.0	3.2	12.5	12.5	50
B2 ^b , C, D, G, H	Turning ^c	-	0.8	3.2	3.2	12.5

For certain applications, e.g. low temperature gases, it may be necessary to stipulate closer control to the surface finish.

a) Ra and Rz are defined in EN ISO 4287.

b) Types B1 and B2 are raised face (type B) flanges with different specified surface roughness values.

B1 : Standard facing for all PN numbers.

B2 : Only if agreed between the purchaser and the flange manufacturer.

c) The term 'turning' includes any method of machine operation producing either serrated concentric or serrated spiral grooves.

Flanges type 05 up to PN 40 and collars (except types 33, 36 and 37) shall have type A facing, other flanges shall have type B1 facings; unless type B2 facing is agreed between the purchaser and the supplier.

Flange Facing Dimensions EN 1092-1

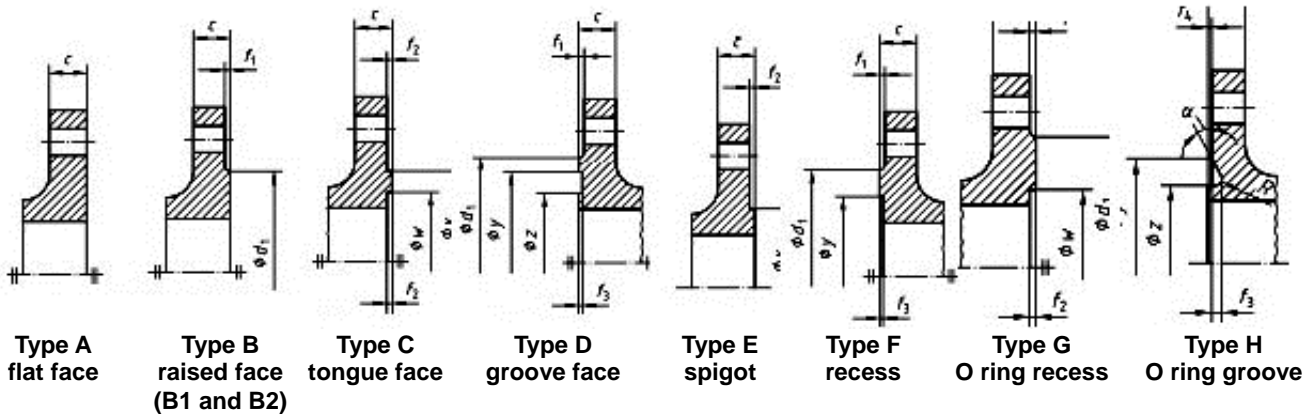

DN	d1											f1	f2	f3	f4	w**	x	y	z**	a≈	R	
	PN2.5*	PN6*	PN10	PN16	PN25	PN40	PN63	PN100	PN160	PN250	PN320											PN400
	mm	mm	mm	mm	mm	mm	mm	mm	mm	mm	mm	mm	mm	mm	Mm	mm	mm	mm		mm		
10	35	35	40	40	40	40	40	40	40	40	40	40	2	4.5	4.0	2.0	24	34	35	23	-	2.5
15	40	40	45	45	45	45	45	45	45	45	45	45					29	39	40	28	-	
20	50	50	58	58	58	58	58	58	58	58	58	58					36	50	51	35		
25	60	60	68	68	68	68	68	68	68	68	68	68					43	57	58	42		
32	70	70	78	78	78	78	78	78	78	78	78	78					51	65	66	50		
40	80	80	88	88	88	88	88	88	88	88	88	88					61	75	76	60	41°	
50	90	90	102	102	102	102	102	102	102	102	102	102					73	87	88	72		
65	110	110	122	122	122	122	122	122	122	122	122	122					95	109	110	94		
80	128	128	138	138	138	138	138	138	138	138	138	138					106	120	121	105		
100	148	148	158	158	162	162	162	162	162	162	162	162					3	5.0	4.5	2.5	129	
125	178	178	188	188	188	188	188	188	188	188	188	188	155	175	176	154						
150	202	202	212	212	218	218	218	218	218	218	218	218	183	203	204	182						
200	258	258	268	268	278	285	285	285	285	285	285	285	239	259	260	238						
250	312	312	320	320	335	345	345	345	345	345	345	345	292	312	313	291						
300	365	365	370	378	395	410	410	410	410	-	-	-	343	363	364	342						
350	415	415	430	438	450	465	465	465	-	-	-	-	395	421	422	394						
400	465	465	482	490	505	535	535	535	-	-	-	-	447	473	474	446						
50	520	520	532	550	555	560	560	560	-	-	-	-	497	523	524	496						
500	570	570	585	610	615	615	615	615	-	-	-	-	549	575	576	548						
600	670	670	685	725	720	735	735	-	-	-	-	-	649	675	676	648	27°					
700	775	775	800	795	820	840	840	-	-	-	-	-	751	777	778	750						
800	880	880	905	900	930	960	960	-	-	-	-	-	856	882	883	855						
900	980	980	1005	1000	1030	1070	1070	-	-	-	-	-	961	987	988	960						
1000	1080	1080	1110	1115	1140	1180	1180	-	-	-	-	-	1062	1092	1094	1060						
1200	1280	1295	1330	1330	1350	1380	1380	-	-	-	-	-	1262	1292	1294	1260						
1400	1480	1510	1535	1530	1560	1600	-	-	-	-	-	-	1462	1492	1494	1460						
1600	1690	1710	1760	1750	1780	1815	-	-	-	-	-	-	1662	1692	1694	1660	28°					
1800	1890	1920	1960	1950	1985	-	-	-	-	-	-	-	1862	1892	1894	1860						
2000	2090	2125	2170	2150	2210	-	-	-	-	-	-	-	2062	2092	2094	2060						
2200	2295	2335	2370	-	-	-	-	-	-	-	-	-	-	-	-	-	-	-	-	-		
2400	2495	2545	2570	-	-	-	-	-	-	-	-	-	-	-	-	-	-	-	-	-		
2600	2695	2750	2780	-	-	-	-	-	-	-	-	-	-	-	-	-	-	-	-	-		
2800	2910	2960	3000	-	-	-	-	-	-	-	-	-	-	-	-	-	-	-	-	-		
3000	3110	3160	3210	-	-	-	-	-	-	-	-	-	-	-	-	-	-	-	-	-		
3200	3310	3370	-	-	-	-	-	-	-	-	-	-	-	-	-	-	-	-	-	-		
3400	3510	3580	-	-	-	-	-	-	-	-	-	-	-	-	-	-	-	-	-	-		
3600	3720	3790	-	-	-	-	-	-	-	-	-	-	-	-	-	-	-	-	-	-		
3800	3920	-	-	-	-	-	-	-	-	-	-	-	-	-	-	-	-	-	-	-		
4000	4120	-	-	-	-	-	-	-	-	-	-	-	-	-	-	-	-	-	-	-		

* Flange facing types C, D, E, F, G and H according to Figure 4 are not used for PN 2,5 and 6.

** Flange facing types G and H according to Figure 4 are only used for PN 10 to PN 40.

Wall thickness and end preparation EN 1092-1

Weld-end preparation for flanges types 11 and 34

Unless otherwise specified, for flanges in accordance with this European Standard the welding end connections given in A1 to A3 shall be used. Additional types of welding ends are specified in EN ISO 9692-2 and example of designs in EN 1708-1 and may be used by agreement between the component or pressure equipment manufacturer and the flange manufacturer.

- Wall thickness $S \leq 3$ mm: Flanges/collars may be delivered with square cut ends.
- Wall thickness $3 < S < 22$: Bevelled ends with an angle of $30^{\circ} \begin{smallmatrix} +5^{\circ} \\ -0^{\circ} \end{smallmatrix}$ and root face of $(1,6 \pm 0,8)$ mm.
- If flange wall thickness (S) > pipe wall thickness (T), the inner diameter shall be chamfered with an angle of $15^{\circ} \begin{smallmatrix} +5^{\circ} \\ -0^{\circ} \end{smallmatrix}$ to match (see A3).

A1 — Welding end connection for wall thickness S up to 22 mm

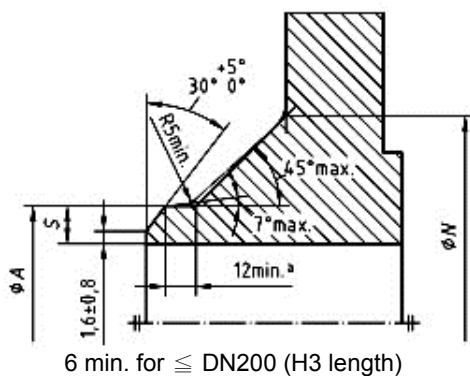

A2 — Welding end connection for wall thickness $S \geq 22$ mm

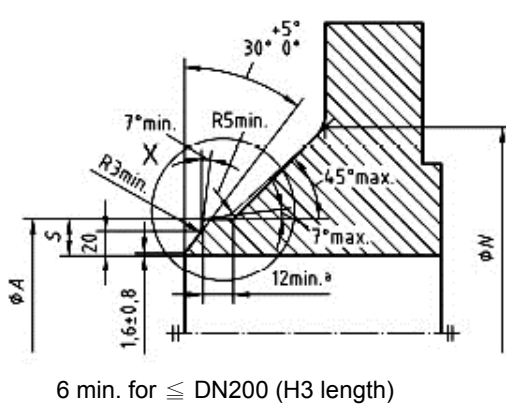

X

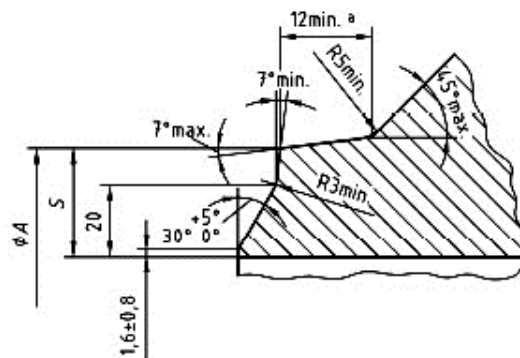

Wall thickness and end preparation EN 1092-1

Weld-end preparation for flanges types 11 and 34

A3 — Permissible bevel design for unequal wall thickness

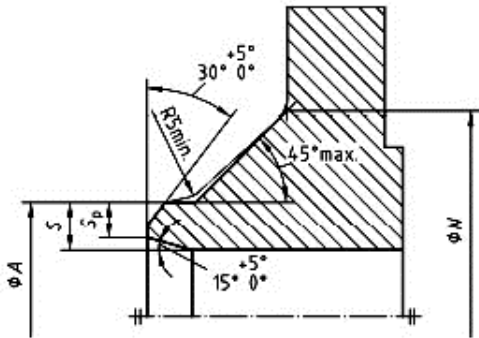

S Flange wall thickness
 Sp Reduced flange wall thickness

- NOTE 1: For flanges required to connect to non-austenitic steel pipe of nominal wall thickness less than 4,8 mm, the welding ends should be finished to a slight chamfer or be square, at the option of the flange manufacturer, if nothing else has been agreed between flange manufacturer and purchaser or pressure equipment manufacturer.
- NOTE 2: For flanges required to connect to austenitic stainless steel pipe of nominal wall thickness 3,2 mm or less, the welding ends should be square cut ends.
- NOTE 3: The mating wall thickness of the flange (*Sp*) shall match to the pipe wall thickness (*T*).

Wall thickness and end preparation EN 1092-1

Wall thickness for flange type 11

ψ A	PN2.5		PN6		PN10		PN16		PN25		PN40		PN63		PN100		
	S	Sp	S	Sp	S	Sp	S	Sp	S	Sp	S	Sp	S	Sp	S	Sp	
17.2	2	2	2	2	2	2	2	2	2	2	2	2	2	2	2	2	
21.3	2	2	2	2	2	2	2	2	2	2	2	2	2	2	3.2	2	
26.9	2.3	2.3	2.3	2.3	2.3	2.3	2.3	2.3	2.3	2.3	2.3	2.3	2.6	2.3	3.2	2.3	
33.7	2.6	2.6	2.6	2.6	2.6	2.6	2.6	2.6	2.6	2.6	2.6	2.6	2.6	2.6	3.6	2.6	
42.4	2.6	2.6	2.6	2.6	2.6	2.6	2.6	2.6	2.6	2.6	2.6	2.6	2.9	2.6	3.6	2.9	
48.3	2.6	2.6	2.6	2.6	2.6	2.6	2.6	2.6	2.6	2.6	2.6	2.6	2.9	2.9	3.6	3.2	
60.3	2.9	2.9	2.9	2.9	2.9	2.9	2.9	2.9	2.9	2.9	2.9	2.9	4	3.2	4	3.6	
76.1	2.9	2.9	2.9	2.9	2.9	2.9	2.9	2.9	2.9	2.9	2.9	2.9	4	3.6	4	4	
88.9	3.2	3.2	3.2	3.2	3.2	3.2	3.2	3.2	3.2	3.2	3.2	3.2	4.5	4	5	5	
114.3	3.6	3.6	3.6	3.6	3.6	3.6	3.6	3.6	3.6	3.6	3.6	3.6	4.5	4.5	5.6	5.6	
139.7	4	4	4	4	4	4	4	4	4	4	4	4	5.6	5.6	6.3	6.3	
168.3	4.5	4.5	4.5	4.5	4.5	4.5	4.5	4.5	4.5	4.5	4.5	4.5	6.3	6.3	8	8	
219.1	6.3	6.3	6.3	6.3	6.3	6.3	6.3	6.3	6.3	6.3	6.3	6.3	7.1	7.1	8.8	8.8	
273.0	6.3	6.3	6.3	6.3	6.3	6.3	6.3	6.3	6.3	7.1	7.1	7.1	7.1	8.8	8.8	10	10
323.9	7.1	7.1	7.1	7.1	7.1	7.1	7.1	7.1	7.1	8	8	8	8	11	10	12.5	12.5
355.6	7.1	7.1	7.1	7.1	7.1	7.1	8	8	8	8	8.8	8.8	12.5	10	14.2	14.2	
406.4	7.1	7.1	7.1	7.1	7.1	7.1	8	8	8.8	8.8	11	11	14.2	11	16	16	
457	7.1	7.1	7.1	7.1	7.1	7.1	8	8	8.8	8.8	12.5	12.5					
508	7.1	7.1	7.1	7.1	7.1	7.1	8	8	10	10	14.2	14.2					
610	7.1	7.1	7.1	7.1	8	7.1	10	8.8	11	11	16	16					
711	7.1	7.1	8	7.1	8.8	8	10	8.8	14.2	12.5							
813	7.1	7.1	8	7.1	8.8	8	12.5	10	16	14.2							
914	7.1	7.1	8	7.1	12.5	10	12.5	10	17.5	16							
1016	7.1	7.1	8	7.1	12.5	10	12.5	10	20	17.5							
1219	8	7.1	8.8	8	12.5	11	14.2	12.5									
1422	8	7.1	8.8	8	14.2	12.5	16	14.2									
1626	8.8	8	10	9	16	14.2	17.5	16									
1829	10	10	11	10	17.5	16	20	17.5									
2032	11	10	12.5	11	17.5	16	22	20									
2235	11	10	14	12.5	20	18											
2438	11	10	15	14.2	22.2	20											
2620	11	10	16	14.2	25	22.2											
2820	11	10	17	16	25	22.2											
3020	11	10	20	16	32	24											
3220	11	10	20	16													
3420	11	10	22	17.5													
3620	11	10	22	17.5													
3820	11	10															
4020	11	10															

Sp Valves shall match those given in EN 10220 respectively EN ISO 1127.

Wall thickness and end preparation EN 1092-1

Wall-end preparation for type 35

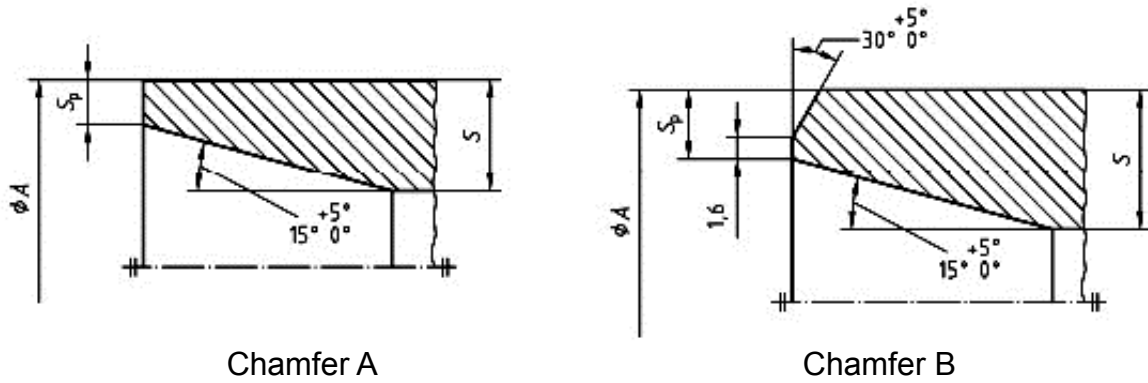

Wall thickness for flange type 35

ϕA	PN2.5		PN6		PN10		PN16		PN25		PN40		Chamfer
	S	Sp	S	Sp	S	Sp	S	Sp	S	Sp	S	Sp	
17.2	3	2	3	2	3	2	3	2	3	2	3	2	A
21.3	3	2	3	2	3	2	3	2	3	2	3	2	
26.9	3	2	3	2	3	2	3	2	3	2	3	2	
33.7	3	2	3	2	3	2	3	2	3	2	3	2	
42.4	3	2	3	2	3	2	3	2	3	2	3	2	
48.3	3	2	3	2	3	2	3	2	3	2	3	2	
60.3	3	2	3	2	3	2	3	2	4	2.6	4	2.6	
76.1	4	2	4	2	4	2	4	2	5	2.6	5	2.6	
88.9	4	2	4	2	4	2	4	2	6	2.6	6	2.6	
114.3	4	2	4	2	4	2	4	2	6	3.2	6	3.2	
139.7	5	2	5	2	5	2	5	2	6	3.2	6	3.2	
168.3	6	2	6	2	6	2	6	2	8	3.2	8	4	B
219.1	6	2.6	6	2.6	6	2.6	6	2.6	8	3.2	10	5	
273	8	3.2	8	3.2	8	3.2	8	3.2	10	5	12	6.3	
323.9	8	3.2	8	3.2	8	3.2	10	4	10	6.3	12	8	
355.6	8	3.2	8	3.2	8	3.2	10	4	12	6.3	14	8	
406.4	8	3.2	8	3.2	8	3.2	12	5	14	8	16	10	
457	8	3.6	8	3.6	8	3.6	12	5	15	8			
508	8	4	8	4	8	4	12	6.3	16	10			
610	8	5	8	5	10	5	12	8	18	10			
711	8	5	8	5	10	6.3	14	8	20	14.2			
813	10	6.3	10	6.3	12	6.3	16	10	20	14.2			
914	10	6.3	10	6.3	12	8	18	10					
1016	12	8	12	8	12	8	18	10					
1219	14	10	14	10	16	10							

Wall thickness and end preparation EN 1092-1

Wall-end preparation for types 36 and 37

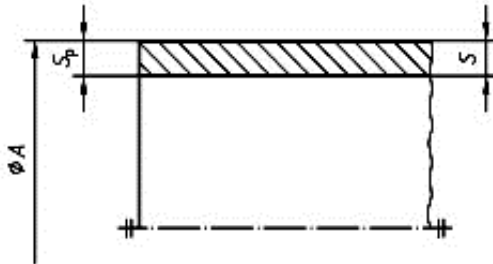

Chamfer A

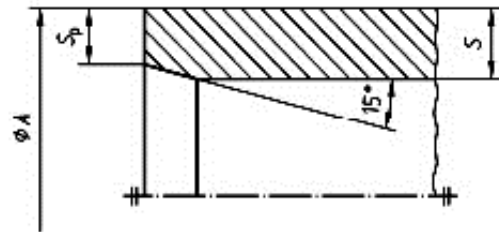

Chamfer B

Tolerance of angle: $+5^\circ$
 -0°

Wall thickness for flange types 36 and 37

ψA	PN2.5 to PN10				PN16				Chamfer
	Type 36		Type 37		Type 36		Type 37		
	S	Sp	S	Sp	S	Sp	S	Sp	
17.2	2	2	2	2	2	2	2	2	A
21.3	2	2	2	2	2	2	2	2	
26.9	2.6	2.6	2	2	2.6	2.6	2	2	
33.7	2.6	2.6	2	2	2.6	2.6	2	2	
42.4	3.2	3.2	2	2	3.2	3.2	2	2	
48.3	3.2	3.2	2	2	3.2	3.2	2	2	
60.3	3.2	3.2	2	2	3.2	3.2	2	2	
76.1	3.2	3.2	2	2	3.2	3.2	2	2	
88.9	3.2	3.2	2	2	3.2	3.2	3.2	3.2	
114.3	3.2	3.2	3.2	3.2	3.2	3.2	3.2	3.2	
139.7	4	3.2	3.2	3.2	4	3.2	3.5	3.2	
168.3	5	3.2	3.5	3.2	5	3.2	4.5	3.2	
219.1	5	3.2	4.5	3.2	6	3.2	5.6	3.2	
273	8	3.2			10	3.2			
323.9	8	3.2			10	4**			
355.6	8	3.2			10	4**			
406.4	8	3.2			10	4**			
457	8*	3.2*							
508*	8*	3.2*							

*These values are valid only for PN 2,5 and PN 6.

** Like chamfer B for Type 35.

EN 1092-1 PN2.5 Flanges

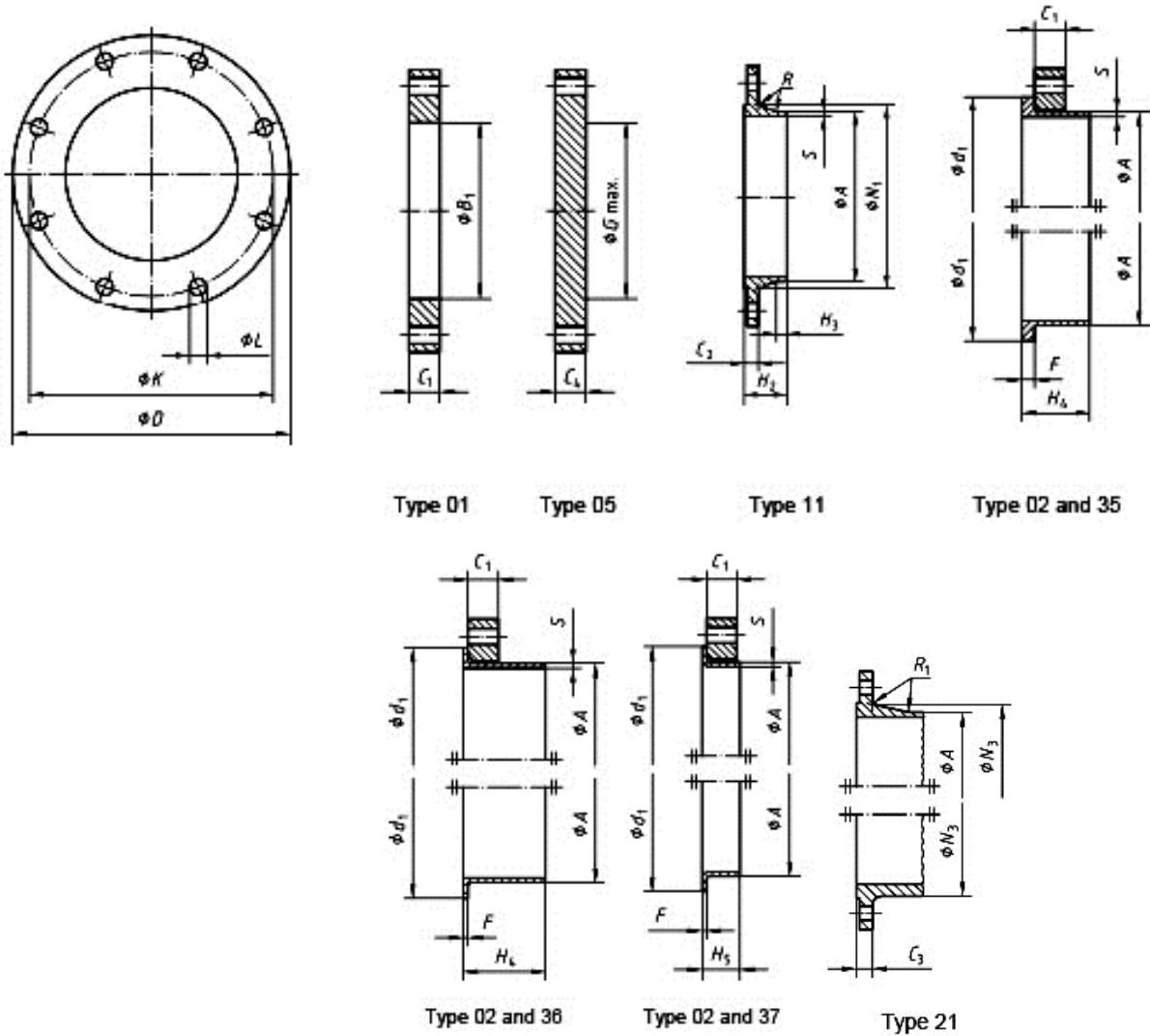

Type 01

Type 05

Type 11

Type 02 and 35

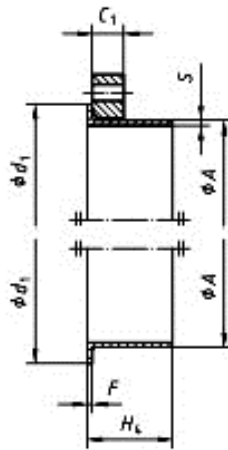

Type 02 and 36

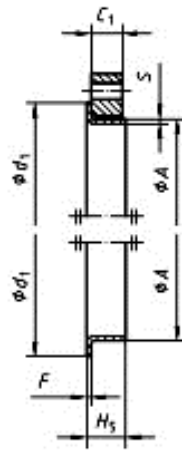

Type 02 and 37

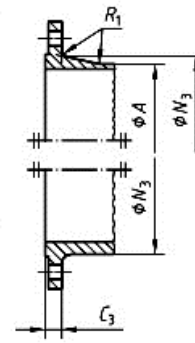

Type 21

Flange type (typ) as in EN 1092-1	
01 (Plate [slip-on] flanges for welding)	21 (Integral flanges)
02 (Loose plate flanges with weld-on plate collar)	35 (Welding neck)
05 (Blank [blind] flanges)	36 (Pressed collar with long neck)
11 (Weld-neck flanges)	37 (Pressed collar)

EN 1092-1 PN2.5 Flanges

DN	Mating dimensions					Outside Diameter of Neck	Bore Diameter				Flange thickness				Collar thickness	Diameter of Shoulders	Length					Neck diameters		Corner Radius	Wall thickness	
	Outside Diameter	Diameter of Bolt Circle	Diameter of Bolt Hole	Bolting			B1	B2	C1	C2	C3	C4	F	G max			H2	H3	H4	H5	N1	N3	R1			S
				No	Size																					
	D	K	L	No	Size		A	B1	B2	C1	C2	C3	C4	F			G max	H2	H3	H4	H5	N1	N3			R1
	Flange type																									
	01, 02, 05, 11, 21					11 21 35-37	01 32	02	01 02	11 21	05	32	35	36	37	05	11	11	35	36	37	11	21	11 13	11 35 36 37	
10	75	50	11	4	M10	17.2	18.0	21	12	12	12	10	5	2.0	2.5	-	28	6	28	35	7	26	20	4		
15	80	55	11	4	M10	21.3	22.0	25	12	12	12	10	5	2.0	2.5	-	30	6	30	38	7	30	26	4		
20	90	65	11	4	M10	26.9	27.5	31	14	14	14	10	6	2.5	3.0	-	32	6	32	40	8	38	34	4		
25	100	75	11	4	M10	33.7	34.5	38	14	14	14	10	7	2.5	3.0	-	35	6	35	40	10	42	44	4		
32	120	90	14	4	M12	42.4	43.5	46	16	14	14	10	8	3.0	3.0	-	35	6	35	42	12	55	54	6		
40	130	100	14	4	M12	48.3	49.5	53	16	14	14	10	8	3.0	3.0	-	38	7	38	45	15	62	64	6		
50	140	110	14	4	M12	60.3	61.5	65	16	14	14	12	8	3.0	3.0	-	38	8	38	45	20	74	74	6		
65	160	130	14	4	M12	76.1	77.5	81	16	14	14	12	8	3.0	3.0	55	38	9	38	45	20	88	94	6		
80	190	150	18	4	M16	88.9	90.5	94	18	16	16	12	10	3.0	4.0	70	42	10	42	50	25	102	110	8		
100	210	170	18	4	M16	114.3	116	120	18	16	16	14	10	4.0	4.0	90	45	10	45	52	25	130	130	8		
125	240	200	18	8	M16	139.7	141.5	145	20	18	18	14	10	4.0	4.0	115	48	10	48	55	25	155	160	8		
150	265	225	18	8	M16	168.3	170.5	174	20	18	18	14	10	5.0	4.0	140	48	12	48	55	25	184	182	10		
200	320	280	18	8	M16	219.1	221.5	226	22	20	20	16	11	5.0	5.0	190	55	15	55	62	30	236	238	10		
250	375	335	18	12	M16	273.0	276.5	281	24	22	22	18	12	8.0	-	235	60	15	60	68	-	290	284	12		
300	440	395	22	12	M20	323.9	327.5	333	24	22	22	18	12	8.0	-	285	62	15	62	68	-	342	342	12		
350	490	445	22	12	M20	355.6	359.5	365	26	22	22	18	13	8.0	-	330	62	15	62	68	-	385	392	12		
400	540	495	22	16	M20	406.4	411.0	416	28	22	22	20	14	8.0	-	380	65	15	65	72	-	438	442	12		
450	595	550	22	16	M20	457.0	462.0	467	30	22	24	20	15	8.0	-	425	65	15	65	72	-	492	494	12		
500	645	600	22	20	M20	508.0	513.5	519	30	24	24	22	16	8.0	-	475	68	15	68	75	-	538	544	12		
600	755	705	26	20	M24	610.0	616.5	622	32	30	30	22	16	-	-	575	70	16	70	-	-	640	642	12		
700	860	810	26	24	M24	711.0		721	40	30	40	-	16	-	-	670	76	16	70	-	-	740	746	12		
800	975	920	30	24	M27	813.0		824	44	30	44	-	16	-	-	770	76	16	70	-	-	842	850	12		
900	1075	1020	30	24	M27	914.0		926	48	30	48	-	16	-	-	860	74	16	70	-	-	942	950	12		
1000	1175	1120	30	28	M27	1016		1028	52	30	52	-	18	-	-	960	74	16	70	-	-	1045	1050	16		
1200	1375	1320	30	32	M27	1219	**	1234	60	32	50	-	20	-	-	1160	94	16	90	-	-	1245	-	16		
1400	1575	1520	30	36	M27	1422		-	-	38	-	-	-	-	-	1346	96	16	-	-	-	1445	-	16		
1600	1790	1730	30	40	M27	1626		-	-	46	-	-	-	-	-	1546	102	20	-	-	-	1645	-	16		
1800	1990	1930	30	44	M27	1829		-	-	46	-	-	-	-	-	1746	110	20	-	-	-	1845	-	16		
2000	2190	2130	30	48	M27	2032		-	-	50	-	-	-	-	-	1950	122	22	-	-	-	2045	-	16		
2200	2405	2340	32	52	M30	2235	-	-	-	56	-	-	-	-	-	-	129	25	-	-	-	2248	-	18		
2400	2605	2540	33	56	M30	2438	-	-	-	62	-	-	-	-	-	-	143	25	-	-	-	2448	-	18		
2600	2805	2740	33	60	M30	2620	-	-	-	64	-	-	-	-	-	-	148	25	-	-	-	2648	-	18		
2800	3030	2960	36	64	M33	2820	-	-	-	74	-	-	-	-	-	-	161	25	-	-	-	2848	-	18		
3000	3230	3160	36	68	M33	3020	-	-	-	80	-	-	-	-	-	-	170	25	-	-	-	3050	-	18		
3200	3430	3360	36	72	M33	3220	-	-	-	84	-	-	-	-	-	-	180	25	-	-	-	3250	-	20		
3400	3630	3560	36	76	M33	3420	-	-	-	90	-	-	-	-	-	-	194	28	-	-	-	3475	-	20		
3600	3840	3770	36	80	M33	3620	-	-	-	96	-	-	-	-	-	-	201	28	-	-	-	3652	-	20		
3800	4045	3970	39*	80	M36	3820	-	-	-	102	-	-	-	-	-	-	212	28	-	-	-	3852	-	20		
4000	4245	4170	39	84	M36	4020	-	-	-	106	-	-	-	-	-	-	226	28	-	-	-	4052	-	20		

See "Wall thickness and end preparation"

Note 1: Dimensions N1 is measured at the intersection of the hub draft angle and the back face of the flange.

Note 2: The centre portion of the face of a flange type 05 need not be machined provided that the diameter of the un-machined portion does not exceed the recommended diameter for G max.

** To be specified by the purchaser.

EN 1092-1 PN6 Flanges

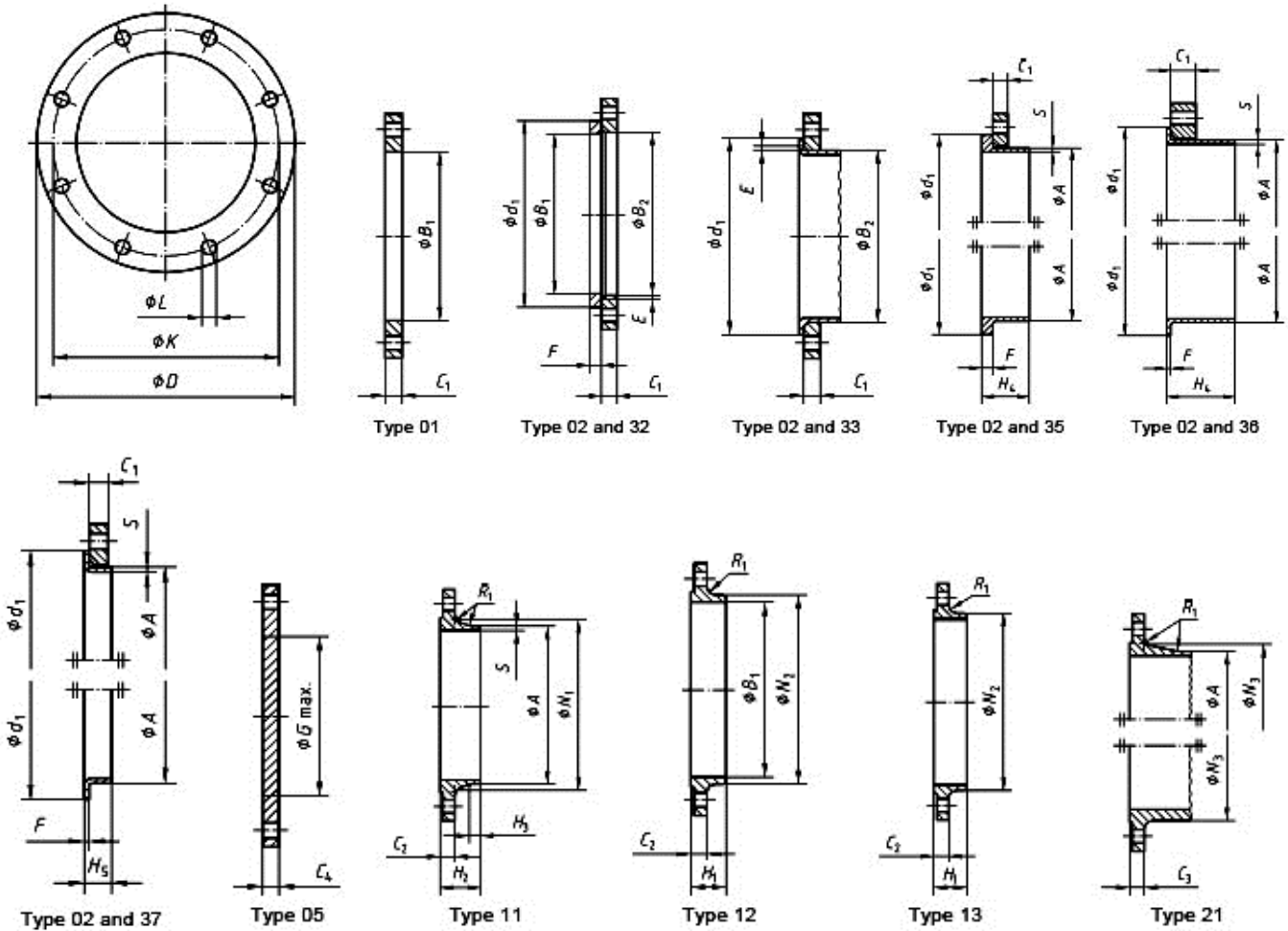

Flange type (typ) as in EN 1092-1	
01 (Plate [slip-on] flanges for welding)	21 (Integral flanges)
02 (Loose plate flanges with weld-on plate collar)	32 (Weld-on plate collars)
05 (Blank [blind] flanges)	33 (Lapped pipe ends without determination of thickness of thickness and height)
11 (Weld-neck flanges)	35 (Welding neck)
12 (Hubbed slip-on flanges for welding)	36 (Pressed collar with long neck)
13 (Hubbed threaded flanges)	37 (Pressed collar)

EN 1092-1 PN6 Flanges

DN	Mating dimensions					Outside Diameter of Neck A	Bore Diameter		Flange thickness			Chamfer E	Collar thickness					Diameter of Shoulders G max	Length					Neck diameters			Corner Radius R1	Wall thickness S
	Outside Diameter D	Diameter of Bolt Circle K	Diameter of Bolt Hole L	Bolting			B1	B2	C1	C2	C3		C4	F	G	H1	H2		H3	H4	H5	N1	N2	N3	R1	S		
				No	Size																							
	Flange type																											
01, 02, 05, 11, 12, 13, 21					11 21*	01 12 32	02	01 02	11 12 13 21	05	02	32	35	36	37	05	12 13	11	11	35	36	37	11	12 13	21	11 12 13 21	11 12 13 21	11 12 13 21
10	75	50	11	4	M10	17.2	18.0	21	12	12	12	3	10	5	2.0	2.5	-	20	28	6	28	35	7	26	25	20	4	
15	80	55	11	4	M10	21.3	22.0	25	12	12	12	3	10	5	2.0	2.5	-	20	30	6	30	38	7	30	30	26	4	
20	90	65	11	4	M10	26.9	27.5	31	14	14	14	4	10	6	2.5	3.0	-	24	32	6	32	40	8	38	40	34	4	
25	100	75	11	4	M10	33.7	34.5	38	14	14	14	4	10	7	2.5	3.0	-	24	35	6	35	40	10	42	50	44	4	
32	120	90	14	4	M12	42.4	43.5	46	16	14	14	5	10	8	3.0	3.0	-	26	35	6	35	42	12	55	60	54	6	
40	130	100	14	4	M12	48.3	49.5	53	16	14	14	5	10	8	3.0	3.0	-	26	38	7	38	45	15	62	70	64	6	
50	140	110	14	4	M12	60.3	61.5	65	16	14	14	5	12	8	3.0	3.0	-	28	38	8	38	45	20	74	80	74	6	
65	160	130	14	4	M12	76.1	77.5	81	16	14	14	6	12	8	3.0	3.0	55	32	38	9	38	45	20	88	100	94	6	
80	190	150	18	4	M16	88.9	90.5	94	18	16	16	6	12	10	3.0	4.0	70	34	42	10	42	50	25	102	110	110	8	
100	210	170	18	4	M16	114.3	116	120	18	16	16	6	14	10	4.0	4.0	90	40	45	10	45	52	25	130	130	130	8	
125	240	200	18	8	M16	139.7	141.5	145	20	18	18	6	14	10	4.0	4.0	115	44	48	10	48	55	25	155	160	160	8	
150	265	225	18	8	M16	168.3	170.5	174	20	18	18	6	14	10	5.0	4.0	140	44	48	12	48	55	25	184	185	182	10	
200	320	280	18	8	M16	219.1	221.5	226	22	20	20	6	16	11	5.0	5.0	190	44	55	15	55	62	30	236	240	238	10	
250	375	335	18	12	M16	273.0	276.5	281	24	22	22	8	18	12	8.0	-	235	44	60	15	60	68	-	290	295	284	12	
300	440	395	22	12	M20	323.9	327.5	333	24	22	22	8	18	12	8.0	-	285	44	62	15	62	68	-	342	355	342	12	
350	490	445	22	12	M20	355.6	359.5	365	26	22	22	8	18	13	8.0	-	330	-	62	15	62	68	-	385	-	392	12	
400	540	495	22	16	M20	406.4	411	416	28	22	22	8	20	14	8.0	-	380	-	65	15	65	72	-	438	-	442	12	
450	595	550	22	16	M20	457.0	462	467	30	22	24	8	20	15	8.0	-	425	-	65	15	72	72	-	492	-	494	12	
500	645	600	22	20	M20	508.0	513.5	519	30	24	24	8	22	16	8.0	-	475	-	68	15	75	75	-	538	-	544	12	
600	755	705	26	20	M24	610.0	616.5	622	32	30	30	8	22	16	-	-	575	-	70	16	70	-	-	640	-	642	12	
700	860	810	26	24	M24	711.0	-	721	40	30	40	4	-	16	-	-	670	-	76	16	70	-	-	740	-	746	12	
800	975	920	30	24	M27	813.0	-	824	44	30	44	4	-	16	-	-	770	-	76	16	70	-	-	842	-	850	12	
900	1075	1020	30	24	M27	914.0	-	926	48	34	48	4	-	16	-	-	860	-	78	16	70	-	-	942	-	950	12	
1000	1175	1120	30	28	M27	1016.0	-	1028	52	38	52	4	-	18	-	-	960	-	82	16	70	-	-	1045	-	1050	16	
1200	1405	1340	33	32	M30	1219.0	**	1234	60	42	60	5	-	20	-	-	1160	-	104	20	90	-	-	1248	-	1264	16	
1400	1630	1560	36	36	M33	1422.0	-	-	42	56	68	-	-	-	-	-	1346	-	114	20	-	-	-	1452	-	1480	16	
1600	1830	1760	36	40	M33	1626.0	-	-	80	63	76	-	-	-	-	-	1546	-	119	20	-	-	-	1655	-	1680	16	
1800	2045	1970	39	44	M36	1829.0	-	-	88	69	84	-	-	-	-	-	1746	-	133	20	-	-	-	1855	-	1878	16	
2000	2265	2180	42	48	M39	2032.0	-	-	96	74	92	-	-	-	-	-	1950	-	146	25	-	-	-	2058	-	2082	16	
2200	2475	2390	42	52	M39	2035.0	-	-	-	81	-	-	-	-	-	-	-	-	154	25	-	-	-	2260	-	-	18	
2400	2685	2600	42	56	M39	2438.0	-	-	-	87	-	-	-	-	-	-	-	-	168	25	-	-	-	2462	-	-	18	
2600	2905	2710	48	60	M45	2620.0	-	-	-	91	-	-	-	-	-	-	-	-	175	25	-	-	-	2665	-	-	18	
2800	3115	3020	48	64	M45	2820.0	-	-	-	101	-	-	-	-	-	-	-	-	188	30	-	-	-	2865	-	-	18	
3000	3315	3220	48	68	M45	3020.0	-	-	-	102	-	-	-	-	-	-	-	-	192	30	-	-	-	3068	-	-	18	
3200	3525	3430	48	72	M45	3220.0	-	-	-	106	-	-	-	-	-	-	-	-	202	30	-	-	-	3272	-	-	20	
3400	3735	3640	48	76	M45	3420.0	-	-	-	110	-	-	-	-	-	-	-	-	214	35	-	-	-	3475	-	-	20	
3600	3970	3860	56	80	M52	3620.0	-	-	-	124	-	-	-	-	-	-	-	-	229	35	-	-	-	3678	-	-	20	

See "Wall thickness and end preparation"

* For flanges type 21 the outside hub diameter approximately corresponds to the outside pipe diameter.

** To be specified by the purchaser.

Note 1: Dimensions N1, N2 and N3 are measured at the intersection of the hub draft angle and the back face of the flange.

Note 2: The centre portion of the face of a flange type 05 need not be machined provided that the diameter of the un-machined portion does not exceed the recommended diameter for G max.

Note 3: For d1 dimensions see document "Flange Facing Dimensions EN 1092-1"

Note 4: Type 33; lapped pipe end without determination of thickness and height.

EN 1092-1 PN10 Flanges

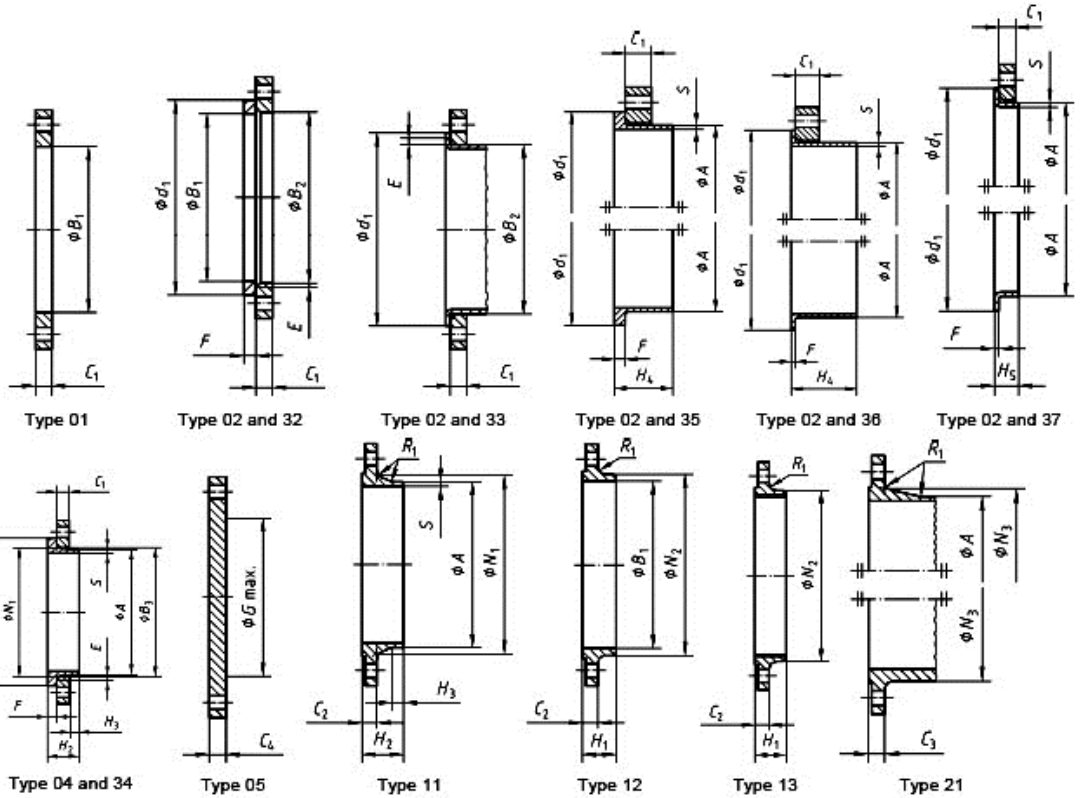
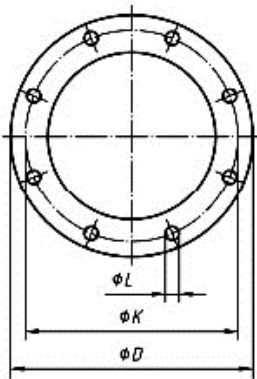

Flange type (typ) as in EN 1092-1	
01 (Plate [slip-on] flanges for welding)	21 (Integral flanges)
02 (Loose plate flanges with weld-on plate collar)	32 (Weld-on plate collars)
04 (Loose plate flanges with weld-neck collar)	33 (Lapped pipe ends without determination of thickness and height)
05 (Blank [blind] flanges)	35 (Weld-neck collars)
11 (Weld-neck flanges)	36 (Pressed collar with long neck)
12 (Hubbed slip-on flanges for welding)	37 (Pressed collar)
13 (Hubbed threaded flanges)	

EN 1092-1 PN10 Flanges

DN	Mating dimensions																			Chamfer	Collar thickness	Diameter of Shoulders	Length					Neck diameters			Corner Radius	Wall thickness
	Outside Diameter	Diameter of Bolt Circle	Diameter of Bolt Hole	Bolting		Outside Diameter of Neck	Bore Diameter			Flange thickness				G max	H1	H2	H3	H4	H5				N1	N2	N3	R1	S					
				No	Size		A	B1	B2	B3	C1	C2	C3															C4	E	F		
	D	K	L	No	Size	A	B1	B2	B3	C1	C2	C3	C4	E	F	G max	H1	H2	H3				H4	H5	N1	N2	N3	R1	S			
	Flange type																															
	01, 02, 04, 05, 11, 12, 13, 21	11 21*** 34*	01 12 32	02	04	01 02 04	11 12 13	21	05	02	32	35	36	37	05	12	11	11	35	36	37	11 34*	12	21	11 13 21	11 12 13 34	37					
10	90	60	14	4	M12	17.2	18.0	21	31	14	16	16	16	3	12	5	2.0	2.5	-	22	35	6	35	35	7	28	30	28	4	1.8		
15	95	65	14	4	M12	21.3	22.0	25	35	14	16	16	16	3	12	5	2.0	2.5	-	22	38	6	38	38	7	32	35	32	4	2.0		
20	105	75	14	4	M12	26.9	27.5	31	42	16	18	18	18	4	14	6	2.5	3.0	-	26	40	6	40	40	8	40	45	40	4	2.3		
25	115	85	14	4	M12	33.7	34.5	38	49	16	18	18	18	4	14	7	2.5	3.0	-	28	40	6	40	40	10	46	52	50	4	2.6		
32	140	100	18	4	M16	42.4	43.5	47	59	18	18	18	18	5	14	8	3.0	3.0	-	30	42	6	42	42	12	56	60	60	6	2.6		
40	150	110	18	4	M16	48.3	49.5	53	67	18	18	18	18	5	14	8	3.0	3.0	-	32	45	7	45	45	15	64	70	70	6	2.6		
50	165	125	18	4	M16	60.3	61.5	65	77	20	18	18	18	5	16	8	3.0	4.0	-	28	45	8	45	45	20	74	84	84	6	2.9		
65	185	145	18	8	M16	76.1	77.5	81	96	20	18	18	18	6	16	8	3.0	4.0	55	32	45	10	45	45	20	92	104	104	6	2.9		
80	200	160	18	8	M16	88.9	90.5	94	108	20	20	20	20	6	16	10	3.0	4.0	70	34	50	10	50	50	25	105	118	120	6	3.2		
100	220	180	18	8	M16	114.3	116.0	120	134	22	20	20	20	6	18	10	4.0	4.0	90	40	52	12	52	52	25	131	140	140	8	3.6		
125	250	210	18	8	M16	139.7	141.5	145	162	22	22	22	22	6	18	10	4.0	4.0	115	44	55	12	55	55	25	156	168	170	8	4.0		
150	285	240	22	8	M20	168.3	170.5	174	188	24	22	22	22	6	20	10	4.0	4.0	140	44	55	12	55	55	25	184	195	190	10	4.5		
200	340	295	22	8	M20	219.1	221.5	226	240	24	24	24	24	6	20	11	5.0	5.0	190	44	62	16	62	62	30	234	246	246	10	6.3		
250	395	350	22	12	M20	273.0	276.5	281	294	26	26	26	26	8	22	12	8.0	-	235	46	68	16	68	68	-	292	298	298	12	6.3		
300	445	400	22	12	M20	323.9	327.5	333	348	26	26	26	26	8	22	12	8.0	-	285	46	68	16	68	68	-	342	350	348	12	7.1		
350	505	460	22	16	M20	355.6	359.5	365	400	30	26	26	26	8	22	13	8.0	-	330	53	68	16	68	68	-	385	400	408	12	7.1		
400	565	515	26	16	M24	406.4	411.0	416	450	32	26	26	26	8	24	14	8.0	-	380	57	72	16	72	72	-	440	456	456	12	7.1		
450	615	565	26	20	M24	457.0	462.0	467	498	36	28	28	28	8	24	15	-	-	425	63	72	16	72	-	-	488	502	502	12	7.1		
500	670	620	26	20	M24	508.0	513.5	519	550	38	28	28	28	8	26	16	-	-	475	67	75	16	75	-	-	542	559	559	12	7.1		
600	780	725	30	20	M27	610.0	616.5	622	650	42	30	34	34	8	26	18	-	-	575	75	82	18	80	-	-	642	658	658	12	-		
700	895	840	30	24	M27	711.0		721	-	50	35				38	8	-	20	-	670	-	85	18	80	-	-	746	-	772	12	-	
800	1015	950	33	24	M30	813.0		824	-	56	38				48	8	-	20	-	770	-	96	18	90	-	-	850	-	876	12	-	
900	1115	1050	33	28	M30	914.0	**	926	-	62	38				50	8	-	22	-	860	-	99	20	95	-	-	950	-	976	12	-	
1000	1230	1160	36	28	M33	1016		1028	-	70	44	**			54	8	-	24	-	960	-	105	20	95	-	-	1052	-	1080	16	-	
1200	1455	1380	39	32	M36	1219		1234	-	83	55				66	8	-	26	-	1160	-	132	25	115	-	-	1256	-	1292	16	-	
1400	1675	1590	42	36	M39	1422	-	-	-	-	65				-	-	-	-	-	-	-	143	25	-	-	-	1460	-	1496	16	-	
1600	1915	1820	48	40	M45	1626	-	-	-	-	75				-	-	-	-	-	-	-	159	25	-	-	-	1666	-	1712	16	-	
1800	2115	2020	48	44	M45	1829	-	-	-	-	85				-	-	-	-	-	-	-	175	30	-	-	-	1868	-	1910	16	-	
2000	2325	2230	48	48	M45	2032	-	-	-	-	90				-	-	-	-	-	-	-	186	30	-	-	-	2072	-	2120	16	-	
2200	2550	2440	56	52	M52	2235	-	-	-	-	**	100			-	-	-	-	-	-	-	202	35	-	-	-	2275	-	-	18	-	
2400	2760	2650	56	56	M52	2438	-	-	-	-	110				-	-	-	-	-	-	-	218	35	-	-	-	2478	-	-	18	-	
2600	2960	2850	56	60	M52	2620	-	-	-	-	110				-	-	-	-	-	-	-	224	40	-	-	-	2680	-	-	18	-	
2800	3180	3070	56	64	M52	2820	-	-	-	-	124				-	-	-	-	-	-	-	244	40	-	-	-	2882	-	-	18	-	
3000	3405	3290	62	68	M56	3020	-	-	-	-	132				-	-	-	-	-	-	-	257	45	-	-	-	3085	-	-	18	-	

See "Wall thickness and end preparation"

* Use is limited up to DN600.
 ** To be specified by the purchaser.
 *** For flanges type 21 the outside hub diameter approximately corresponds to the outside pipe diameter.
 Note 1: Dimensions N1, N2 and N3 are measured at the intersection of the hub draft angle and the back face of the flange.
 Note 2: The centre portion of the face of a flange type 05 need not be machined provided that the diameter of the un-machined portion does not exceed the recommended diameter for G max.
 Note 3: For d1 dimensions see document "Flange Facing Dimensions EN 1092-1".
 Note 4: Type 33; lapped pipe end without determination of thickness and height.

EN 1092-1 PN16 Flanges

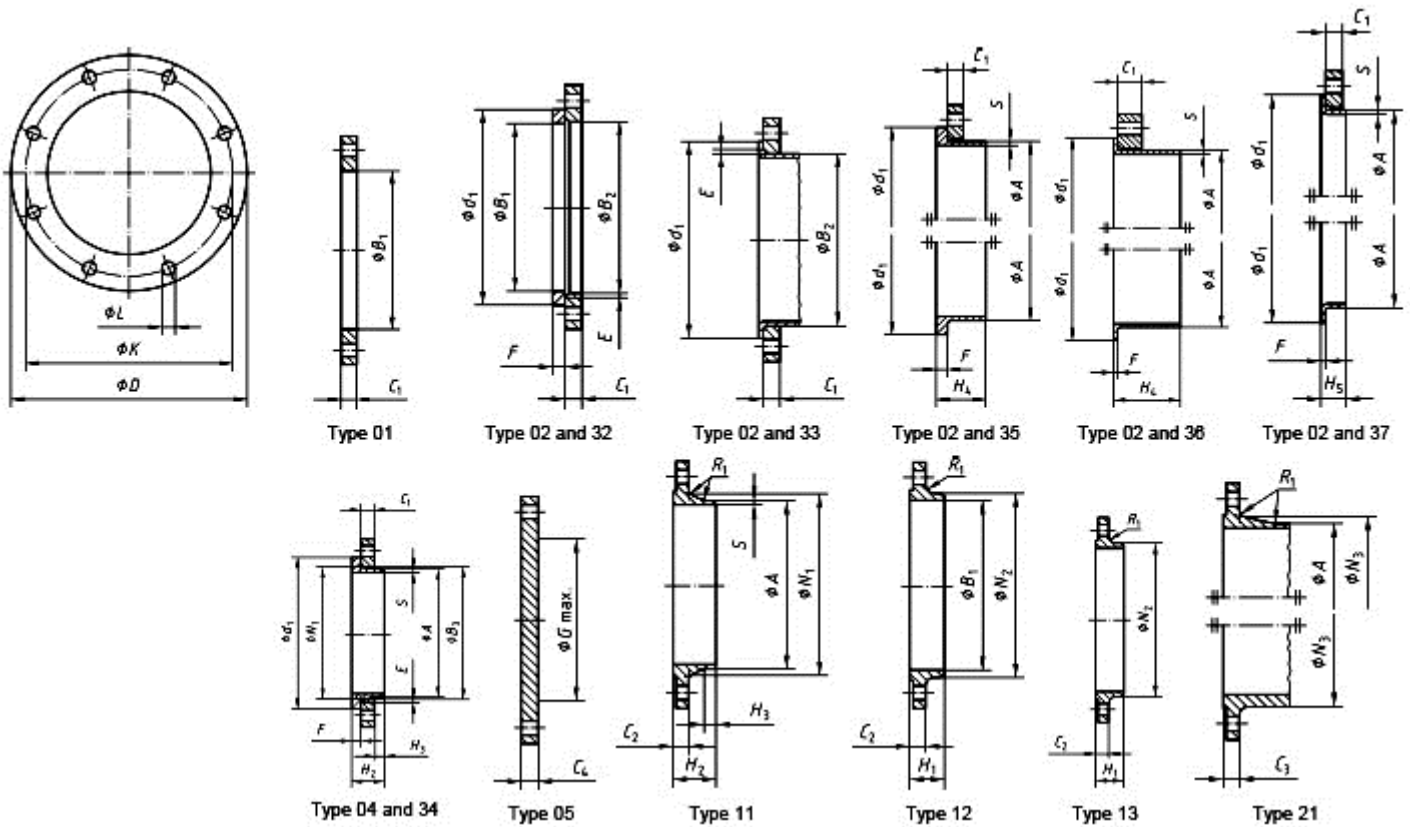

Flange type (typ) as in EN 1092-1	
01 (Plate [slip-on] flanges for welding)	21 (Integral flanges)
02 (Loose plate flanges with weld-on plate collar)	32 (Weld-on plate collars)
04 (Loose plate flanges with weld-neck collar)	33 (Lapped pipe ends without determination of thickness and height)
05 (Blank [blind] flanges)	34 (Weld-neck collars)
11 (Weld-neck flanges)	35 (Weldring neck)
12 (Hubbed slip-on flanges for welding)	36 (Pressed collar with long neck)
13 (Hubbed threaded flanges)	37 (Pressed collar)

EN 1092-1 PN16 Flanges

DN	Mating dimensions						Outside Diameter of Neck	Bore Diameter			Flange thickness				Chamfer	Collar thickness					Diameter of Shoulders	Length					Neck diameters			Corner Radius	Wall thickness				
	Outside Diameter	Diameter of Bolt Circle	Diameter of Bolt Hole	Bolting		A		B1	B2	B3	C1	C2	C3	C4		E	F					G max	H1	H2	H3	H4	H5	N1	N2			N3	R1	S	
	D	K	L	No	Size			01	02	04	01	11	21	05			02	32	35	36			37	05	12	11	11	35	36			37	11	12	21
Flange type																																			
10	90	60	14	4	M12	17.2	18.0	21	31	14	16	16	16	3	12	5	2.0	2.5	-	22	35	6	35	35	7	28	30	28	4	1.8					
15	95	65	14	4	M12	21.3	22.0	25	35	14	16	16	16	3	12	5	2.0	2.5	-	22	38	6	38	38	7	32	35	32	4	2.0					
20	105	75	14	4	M12	26.9	27.5	31	42	16	18	18	18	4	14	6	2.5	3.0	-	26	40	6	40	40	8	40	45	40	4	2.3					
25	115	85	14	4	M12	33.7	34.5	38	49	16	18	18	18	4	14	7	2.5	3.0	-	28	40	6	40	40	10	46	52	50	4	2.6					
32	140	100	18	4	M16	42.4	43.5	47	59	18	18	18	18	5	14	8	3.0	3.0	-	30	42	6	42	42	12	56	60	60	6	2.6					
40	150	110	18	4	M16	48.3	49.5	53	67	18	18	18	18	5	14	8	3.0	3.0	-	32	45	7	45	45	15	64	70	70	6	2.6					
50	165	125	18	4	M16	60.3	61.5	65	77	20	18	18	18	5	16	8	3.0	4.0	-	28	45	8	45	45	20	74	84	84	6	2.9					
65	185	145	18	8 a	M16	76.1	77.5	81	96	20	18	18	18	6	16	8	3.0	4.0	55	32	45	10	45	45	20	92	104	104	6	2.9					
80	200	160	18	8	M16	88.9	90.5	94	108	20	20	20	20	6	16	10	3.0	4.0	70	34	50	10	50	50	25	105	118	120	6	3.2					
100	220	180	18	8	M16	114.3	116.0	120	134	22	20	20	20	6	18	10	4.0	4.0	90	40	52	12	52	52	25	131	140	140	8	3.6					
125	250	210	18	8	M16	139.7	141.5	145	162	22	22	22	22	6	18	10	4.0	4.0	115	44	55	12	55	55	25	156	168	170	8	4.0					
150	285	240	22	8	M20	168.3	170.5	174	188	24	22	22	22	6	20	10	5.0	5.0	140	44	55	12	55	55	25	184	195	190	10	4.5					
200	340	295	22	12	M20	219.1	221.5	226	240	26	24	24	24	6	20	11	6.0	6.0	190	44	62	16	62	62	30	235	246	246	10	6.3					
250	405	355	26	12	M24	273.0	276.5	281	294	29	26	26	26	8	22	12	10.0	-	235	46	70	16	70	68	-	292	298	296	12	6.3					
300	460	410	26	12	M24	323.9	327.5	333	348	32	28	28	28	8	24	14	10.0	-	285	46	78	16	78	68	-	344	350	350	12	7.1					
350	520	470	26	16	M24	355.6	359.5	365	400	35	30	30	30	8	26	18	10.0	-	330	57	82	16	82	68	-	390	400	410	12	8.0					
400	580	525	30	16	M27	406.4	411.0	416	454	38	32	32	32	8	28	20	10.0	-	380	63	85	16	85	72	-	445	456	458	12	8.0					
450	640	585	30	20	M27	457.0	462.0	467	500	42	34	40	40	8	30	22	-	-	425	68	83	16	87	-	-	490	502	516	12	8.0					
500	715	650	33	20	M30	508.0	513.5	519	556	46	36	44	44	8	32	22	-	-	475	73	84	16	90	-	-	548	559	576	12	8.0					
600	840	770	36	20	M33	610.0	616.5	622	660	55	40	54	54	8	32	24	-	-	575	83	88	18	95	-	-	670	658	690	12	8.8					
700	910	840	36	24	M33	711.0		721	-	63	40			58	8	-	26	-	670	83	104	18	100	-	-	755	760	760	12	-					
800	1025	950	39	24	M36	813.0	**	824	-	74	41			62	8	-	28	-	770	90	108	20	105	-	-	855	864	862	12	-					
900	1125	1050	39	28	M36	914.0		926	-	82	48			64	8	-	30	-	860	94	118	20	110	-	-	955	968	962	12	-					
1000	1255	1170	42	28	M39	1016		1030	-	90	59			68	8	-	35	-	960	100	137	22	120	-	-	1058	1072	1076	16	-					
1200	1485	1390	48	32	M45	1219	-	-	-		78	**		-	-	-	-	-	1160	-	160	30	-	-	-	1262	-	1282	16	-					
1400	1685	1590	48	36	M45	1422	-	-	-		84			-	-	-	-	-	1346	-	177	30	-	-	-	1465	-	1482	16	-					
1600	1930	1820	56	40	M52	1626	-	-	-	**	102			-	-	-	-	-	1546	-	204	35	-	-	-	1668	-	1696	16	-					
1800	2130	2020	56	44	M52	1829	-	-	-		110			-	-	-	-	-	1746	-	218	35	-	-	-	1870	-	1896	16	-					
2000	2345	2230	62	48	M56	2032	-	-	-		124			-	-	-	-	-	1950	-	238	40	-	-	-	2072	-	2100	16	-					

See "Wall thickness and end preparation"

(a) According to EN 1092-2 (Cast Iron Flanges) and EN1092-3 (Copper Alloy Flanges), the flanges in this DN and PN may be supplied with 4 holes. Where steel flanges are required with 4 holes, these may be supplied by agreement between flange manufacturer and purchaser.

* Use is limited up to DN600.

** To be specified by the purchaser.

*** For flanges type 21 the outside hub diameter approximately corresponds to the outside pipe diameter.

Note 1: Dimensions N1, N2 and N3 are measured at the intersection of the hub draft angle and the back face of the flange.

Note 2: The centre portion of the face of a flange type 05 need not be machined provided that the diameter of the un-machined portion does not exceed the recommended diameter for G max.

Note 3: For d1 dimensions see document "Flange Facing Dimensions EN 1092-1".

Note 4: Type 33: lapped pipe end without determination of thickness and height.

EN 1092-1 PN25 Flanges

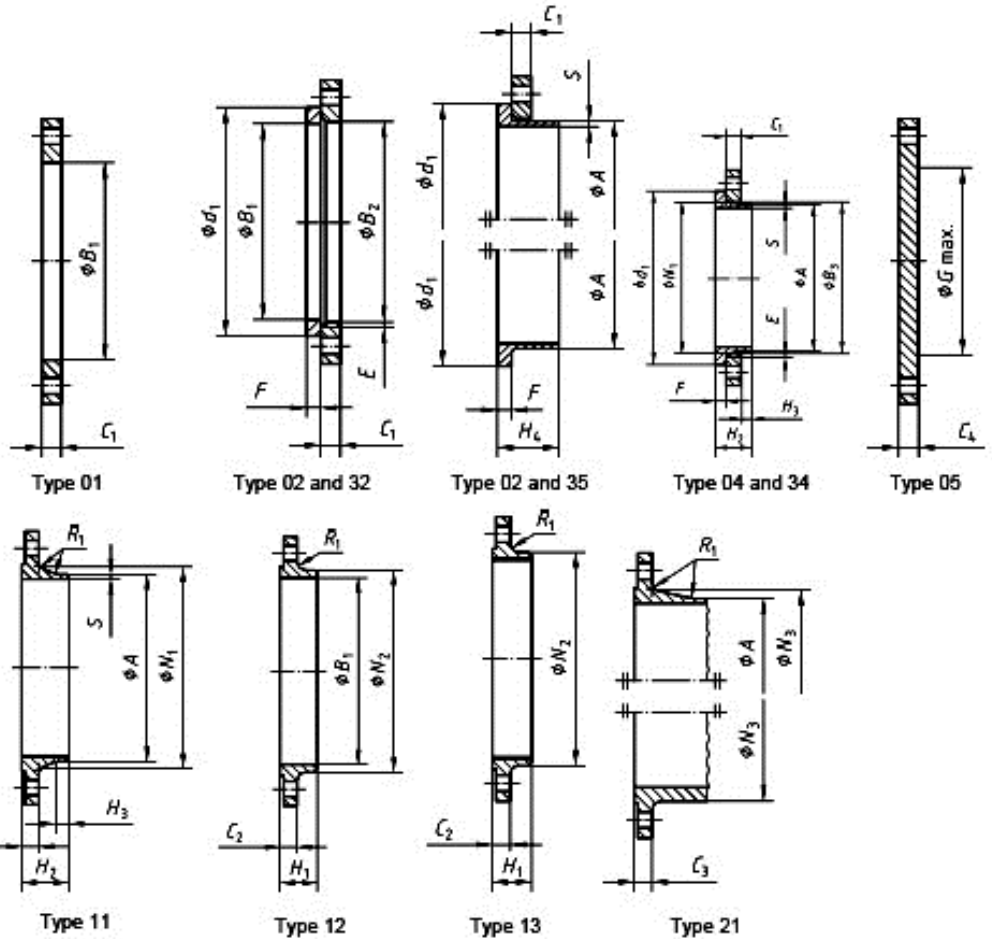
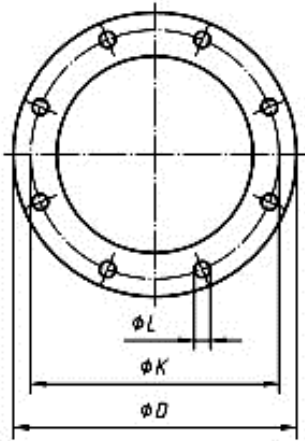

Flange type (typ) as in EN 1092-1	
01 (Plate [slip-on] flanges for welding)	13 (Hubbed threaded flanges)
02 (Loose plate flanges with weld-on plate collar)	21 (Integral flanges)
04 (Loose plate flanges with weld-neck collar)	32 (Weld-on plate collars)
05 (Blank [blind] flanges)	34 (Weld-neck collars)
11 (Weld-neck flanges)	35 (Weldring neck)
12 (Hubbed slip-on flanges for welding)	

EN 1092-1 PN25 Flanges

DN	Mating dimensions					Outside Diameter of Neck	Bore Diameter			Flange thickness				Chamfer	Collar thickness	Diameter of Shoulders	Length				Neck diameters			Corner Radius	Wall thickness					
	Outside Diameter	Diameter of Bolt Circle	Diameter of Bolt Hole	Bolting			B1	B2	B3	C1	C2	C3	C4				E	F	G max	H1	H2	H3	H4			N1	N2	N3	R1	S
	D	K	L	No	Size		A																							
	Flange type																													
					11 21*** 34* 35	01 12 32	02	04	01 02 04	11 12 13	21	05	02 04	32 34 35	05	12 13	11 34*	11 34*	35	11 34	12 13	21	11 12 13 21 34	34	11 35					
10	90	60	14	4	M12	17.2	18.0	21	31	14	16	16	16	3	12	5	-	22	35	6	35	28	30	28	4	1.8				
15	95	65	14	4	M12	21.3	22.0	25	35	14	16	16	16	3	12	5	-	22	38	6	38	32	35	32	4	2.0				
20	105	75	14	4	M12	26.9	27.5	31	42	16	18	18	18	4	14	6	-	26	40	6	40	40	45	40	4	2.3				
25	115	85	14	4	M12	33.7	34.5	38	49	16	18	18	18	4	14	7	-	28	40	6	40	46	52	50	4	2.6				
32	140	100	18	4	M16	42.4	43.5	47	59	18	18	18	18	5	14	8	-	30	42	6	42	56	60	60	6	2.6				
40	150	110	18	4	M16	48.3	49.5	53	67	18	18	18	18	5	14	8	-	32	45	7	45	64	70	70	6	2.6				
50	165	125	18	4	M16	60.3	61.5	65	77	20	20	20	20	5	16	10	-	34	48	8	48	75	84	84	6	2.9				
65	185	145	18	8	M16	76.1	77.5	81	96	22	22	22	22	6	16	11	55	38	52	10	52	90	104	104	6	2.9				
80	200	160	18	8	M16	88.9	90.5	94	114	24	24	24	24	6	18	12	70	40	58	12	58	105	118	120	8	3.2				
100	235	190	22	8	M20	114.3	116.0	120	138	26	24	24	24	6	20	14	90	44	65	12	65	134	145	142	8	3.6				
125	270	220	26	8	M24	139.7	141.5	145	166	28	26	26	26	6	22	16	115	48	68	12	68	162	170	162	8	4.0				
150	300	250	26	8	M24	168.3	170.5	174	194	30	28	28	28	6	24	18	140	52	75	12	75	192	200	192	10	4.5				
200	360	310	26	12	M24	219.1	221.5	226	250	32	30	30	30	6	26	18	190	52	80	16	80	244	256	252	10	6.3				
250	425	370	30	12	M27	273.0	276.5	281	302	35	32	32	32	8	26	18	235	60	88	18	88	298	310	304	12	7.1				
300	485	430	30	16	M27	323.9	327.5	333	356	38	34	34	34	8	28	20	285	67	92	18	92	352	364	364	12	8.0				
350	555	490	33	16	M30	355.6	359.5	365	408	42	38	38	38	8	32	22	332	72	100	20	100	398	418	418	12	8.0				
400	620	550	36	16	M33	406.4	411.0	416	462	48	40	40	40	8	34	24	380	78	110	20	110	452	472	472	12	8.8				
450	670	600	36	20	M33	457.0	462.0	467	510	54	46	46	50	8	36	26	425	84	110	20	110	500	520	520	12	8.8				
500	730	660	36	20	M33	508.0	513.5	519	568	58	48	48	51	8	38	28	475	90	125	20	125	558	580	580	12	10				
600	840	770	39	20	M36	610.0	616.5	622	670	68	48	58	66	8	40	30	575	100	125	20	115	660	684	684	12	11				
700	960	875	42	24	M39	711.0		721	-	85	50			8	-	30	-	-	129	20	125	760	-	780	12	-				
800	1085	990	48	24	M45	813.0	**	824	-	95	53			8	-	35	-	-	138	22	135	864	-	882	12	-				
900	1185	1090	48	28	M45	914.0		-	-	**	57	**	**	-	-	-	-	-	148	24	-	968	-	982	12	-				
1000	1320	1210	56	28	M52	1016	-	-	-		63			-	-	-	-	-	160	24	-	1070	-	1086	16	-				
1200	1530	1420	56	32	M52	1219	To be specified by the purchaser																							
1400	1755	1640	62	36	M56	1422																								
1600	1975	1860	62	40	M56	1626																								
1800	2195	2070	70	44	M64	1829																								
2000	2425	2300	70	48	M64	2032																								

See t "Wall thickness and end preparation"

* Use is limited up to DN500.

** To be specified by the purchaser.

*** For flanges type 21 the outside hub diameter approximately corresponds to the outside pipe diameter.

Note 1: Dimensions N1, N2 and N3 are measured at the intersection of the hub draft angle and the back face of the flange.

Note 2: The centre portion of the face of a flange type 05 need not be machined provided that the diameter of the un-machined portion does not exceed the recommended diameter for G max.

Note 3: For d1 dimensions see document "Flange Facing Dimensions EN 1092-1".

EN 1092-1 PN40 Flanges

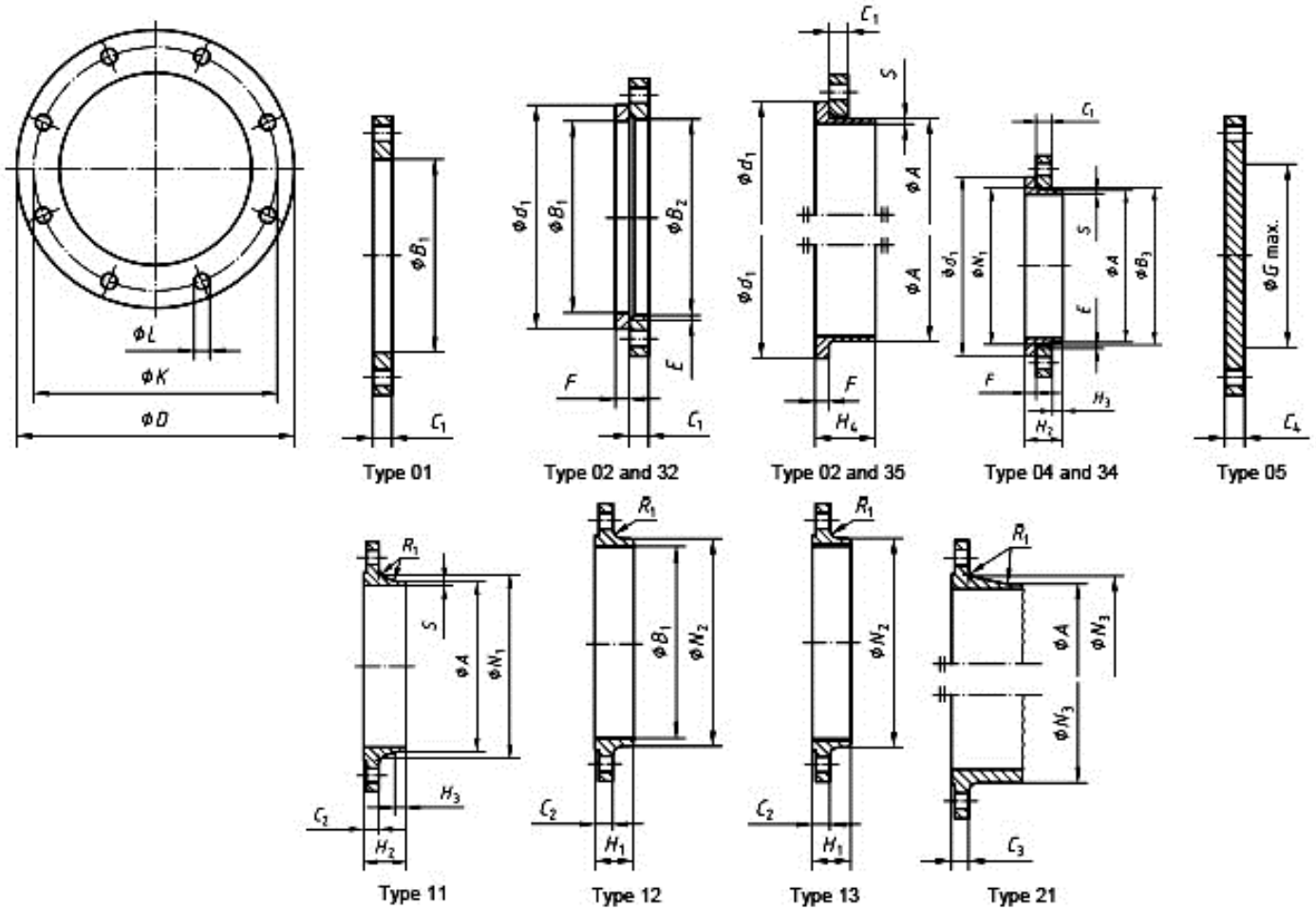

Flange type (typ) as in EN 1092-1	
01 (Plate [slip-on] flanges for welding)	13 (Hubbed threaded flanges)
02 (Loose plate flanges with weld-on plate collar)	21 (Integral flanges)
04 (Loose plate flanges with weld-neck collar)	32 (Weld-on plate collars)
05 (Blank [blind] flanges)	34 (Weld-neck collars)
11 (Weld-neck flanges)	35 (Welding neck)
12 (Hubbed slip-on flanges for welding)	

EN 1092-1 PN40 Flanges

DN	Mating dimensions																								Corner Radius	Wall thickness
	Outside Diameter	Diameter of Bolt Circle	Diameter of Bolt Hole	Bolting		Outside Diameter of Neck	Bore Diameter			Flange thickness				Chamfer	Collar thickness	Diameter of Shoulders	Length				Neck diameters					
				No	Size		B1	B2	B3	C1	C2	C3	C4				E	F	G max	H1	H2	H3	H4	N1		
	D	K	L	No	Size	A	B1	B2	B3	C1	C2	C3	C4	E	F	G max	H1	H2	H3	H4	N1	N2	N3	R1		
Flange type																										
					11 21***	01 12 32	02	04	01 02 04	11 12 13	21	05	02 04	32 34*	35	05	12 13	11 34*	11 34*	35	11 34	12 13	21	11 12 13 21	34*	11 35
10	90	60	14	4	M12	17.2	18.0	21	31	14	16	16	16	3	12	5	-	22	35	6	35	28	30	28	4	1.8
15	95	65	14	4	M12	21.3	22.0	25	35	14	16	16	16	3	12	5	-	22	38	6	38	32	35	32	4	2.0
20	105	75	14	4	M12	26.9	27.5	31	42	16	18	18	18	4	14	6	-	26	40	6	40	40	45	40	4	2.3
25	115	85	14	4	M12	33.7	34.5	38	49	16	18	18	18	4	14	7	-	28	40	6	40	46	52	50	4	2.6
32	140	100	18	4	M16	42.4	43.5	47	59	18	18	18	18	5	14	8	-	30	42	6	42	56	60	60	6	2.6
40	150	110	18	4	M16	48.3	49.5	53	67	18	18	18	18	5	14	8	-	32	45	7	45	64	70	70	6	2.6
50	165	125	18	4	M16	60.3	61.5	65	77	20	20	20	20	5	16	10	-	34	48	8	48	75	84	84	6	2.9
65	185	145	18	8	M16	76.1	77.5	81	96	22	22	22	22	6	16	11	55	38	52	10	52	90	104	104	6	2.9
80	200	160	18	8	M16	88.9	90.5	94	114	24	24	24	24	6	18	12	70	40	58	12	58	105	118	120	8	3.2
100	235	190	22	8	M20	114.3	116.0	120	138	26	24	24	24	6	20	14	90	44	65	12	65	134	145	142	8	3.6
125	270	220	26	8	M24	139.7	141.5	145	166	28	26	26	26	6	22	16	115	48	68	12	68	162	170	162	8	4.0
150	300	250	26	8	M24	168.3	170.5	174	194	30	28	28	28	6	24	18	140	52	75	12	75	192	200	192	10	4.5
200	375	320	30	12	M27	219.1	221.5	226	250	36	34	34	36	6	28	20	190	52	88	16	88	244	260	254	10	6.3
250	450	385	33	12	M30	273.0	276.5	281	312	42	38	38	38	8	30	22	235	60	105	18	105	306	312	312	12	7.1
300	515	450	33	16	M30	323.9	327.5	333	368	52	42	42	42	8	34	25	285	67	115	18	115	362	380	376	12	8.0
350	580	510	36	16	M33	355.6	359.5	365	418	58	46	46	46	8	32	28	330	72	125	20	125	408	424	432	12	8.8
400	660	585	39	16	M36	406.4	411.0	416	472	65	50	50	50	8	42	32	380	78	135	20	135	462	478	498	12	11.0
450	685	610	39	20	M36	457.0	462.0	467	510		57	57	57	8	46	-	425	84	135	20	-	500	522	522	12	12.5
500	755	670	42	20	M39	508.0	513.5	519	572	**	57	57	57	8	50	-	475	90	140	20	-	562	576	576	12	14.2
600	890	795	48	20	M45	610.0	616.5	622	676		72	72	72	8	40	-	575	100	150	20	-	666	686	686	12	16.0
700	995	900	48	24	M45	To be specified by the purchaser																				
800	1140	1030	56	24	M52																					
900	1250	1140	56	28	M52																					
1000	1360	1250	56	28	M52																					
1200	1575	1460	62	32	M56																					
1400	1795	1680	62	36	M56																					
1600	2025	1900	70	40	M64																					
1800	2195	2070	70	44	M64																					
2000	2425	2300	70	48	M64																					

See "Wall thickness and end preparation"

* Use is limited up to DN600.

** To be specified by the purchaser.

*** For flanges type 21 the outside hub diameter approximately corresponds to the outside pipe diameter.

Note 1: Dimensions N1, N2 and N3 are measured at the intersection of the hub draft angle and the back face of the flange.

Note 2: The centre portion of the face of a flange type 05 need not be machined provided that the diameter of the un-machined portion does not exceed the recommended diameter for G max.

Note 3: For d1 dimensions see document "Flange Facing Dimensions EN 1092-1".

EN 1092-1 PN63 Flanges

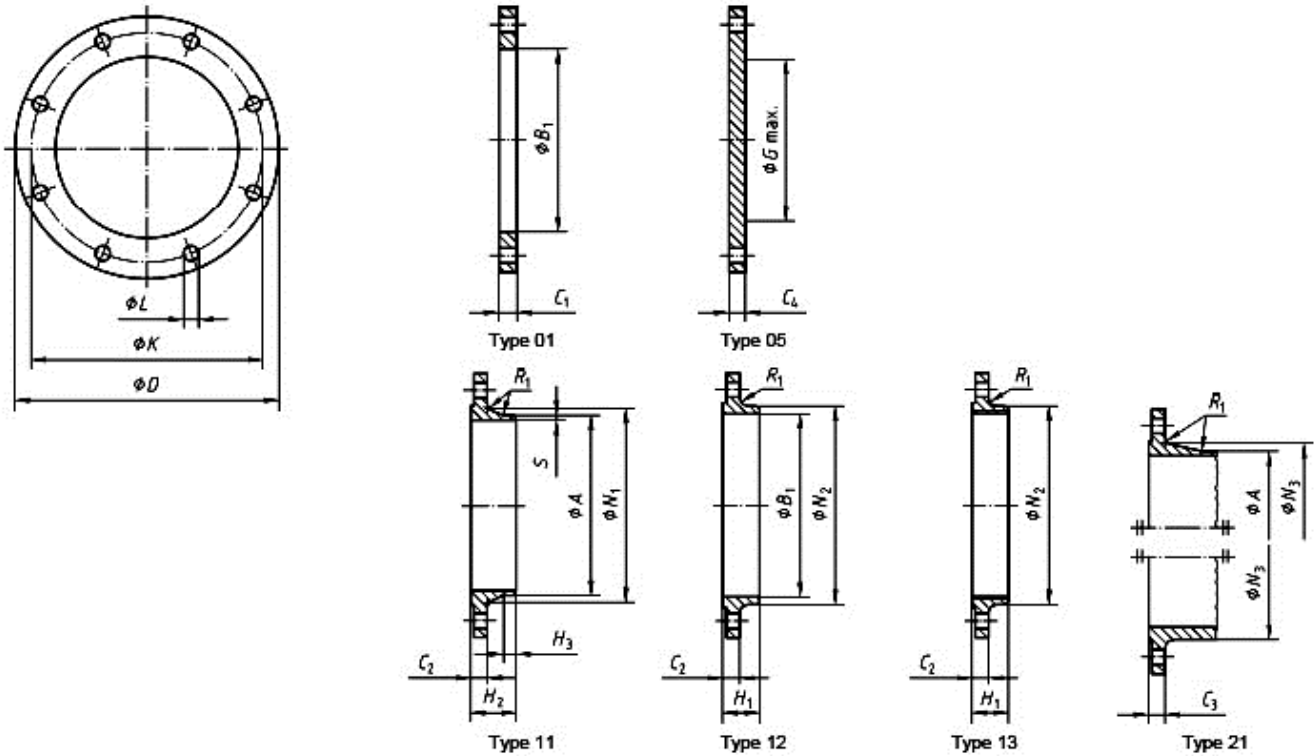

Flange type (typ) as in EN 1092-1	
01 (Plate [slip-on] flanges for welding)	12 (Hubbed slip-on flanges for welding)
05 (Blank [blind] flanges)	13 (Hubbed threaded flanges)
11 (Weld-neck flanges)	21 (Integral flanges)

EN 1092-1 PN63 Flanges

DN	Mating dimensions					Outside Diameter of Neck	Bore Diameter	Flange thickness				Diameter of Shoulders	Length			Neck diameters			Corner Radius	Wall thickness					
	Outside Diameter	Diameter of Bolt Circle	Diameter of Bolt Hole	Bolting				A	B1	C1	C2		C3	C4	G max	H1	H2	H3			N1	N2	N3	R1	S
	D	K	L	No	Size																				
	Flange type																								
	01, 05, 11, 12, 13, 21					11 21***	01 12	01	11 12 13	21	05	05	12 13	11	11	11	12 13	21	11 12 13 21	11					
10	100	70	14	4	M12	17.2	18.0	20	20	20	20	-	28	45	6	32	40	40	4						
15	105	75	14	4	M12	21.3	22.0	20	20	20	20	-	28	45	6	34	43	45	4						
20	130	90	18	4	M16	26.9	27.5	22	22	22	22	-	30	48	8	42	52	50	4						
25	140	100	18	4	M16	33.7	34.5	24	24	24	24	-	32	58	8	52	60	61	4						
32	155	110	22	4	M20	42.4	43.5	24	24	26	24	-	32	60	8	62	68	68	6						
40	170	125	22	4	M20	48.3	49.5	26	26	26	26	-	34	62	10	70	80	82	6						
50	180	135	22	4	M20	60.3	61.5	26	26	26	26	-	36	62	10	82	90	90	6						
65	205	160	22	8	M20	76.1	77.5	26	26	26	26	45	40	68	12	98	112	105	6						
80	215	170	22	8	M20	88.9	90.5	30	28	28	28	60	44	72	12	112	125	122	8						
100	250	200	26	8	M24	114.3	116.0	32	30	30	30	80	52	78	12	138	152	146	8						
125	295	240	30	8	M27	139.7	141.5	34	34	34	34	105	56	88	12	168	185	177	8						
150	345	280	33	8	M30	168.3	170.5	36	36	36	36	130	60	95	12	202	215	204	10						
200	415	345	36	12	M33	219.1	221.5	48	42	42	42	180	-	110	16	256	-	264	10						
250	470	400	36	12	M33	273.0	276.5	55	46	46	46	220	-	125	18	316	-	320	12						
300	530	460	36	16	M33	323.9	327.5	65	52	52	52	270	-	140	18	372	-	378	12						
350	600	525	39	16	M36	355.6	359.5	72	56	56	56	310	-	150	20	420	-	434	12						
400	670	585	42	16	M39	406.4	411.0	80	60	60	60	360	-	160	20	475	-	490	12						
500	800	705	48	20	M45	To be specified by the purchaser																			
600	930	820	56	20	M52																				
700	1045	935	56	24	M52																				
800	1165	1050	62	24	M56																				
900	1285	1170	62	28	M56																				
1000	1415	1290	70	28	M64																				
1200	1665	1530	78	32	M72x6																				

See "Wall thickness and end preparation"

*** For flanges type 21 the outside hub diameter approximately corresponds to the outside pipe diameter.
 Note 1: Dimensions N1, N2 and N3 are measured at the intersection of the hub draft angle and the back face of the flange.
 Note 2: The centre portion of the face of a flange type 05 need not be machined provided that the diameter of the un-machined portion does not exceed the recommended diameter for G max.
 Note 3: For d1 dimensions see document "Flange Facing Dimensions EN 1092-1".

EN 1092-1 PN100 Flanges

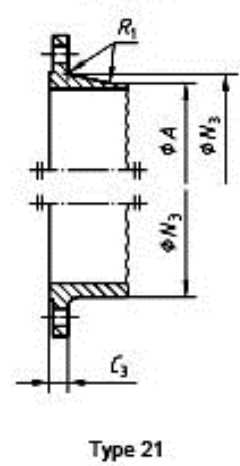
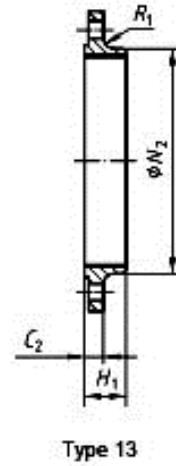
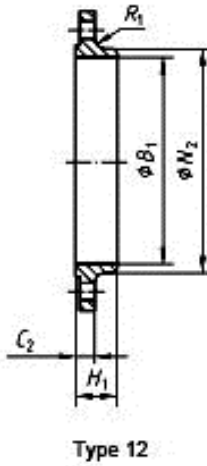
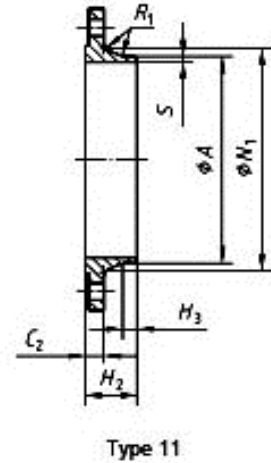
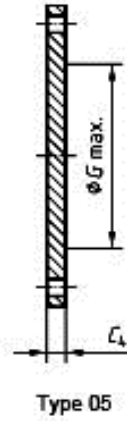
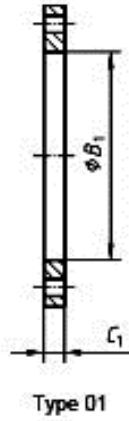
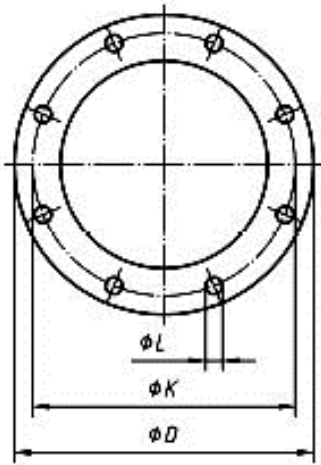

Flange type (typ) as in EN 1092-1	
01 (Plate [slip-on] flanges for welding)	12 (Hubbed slip-on flanges for welding)
05 (Blank [blind] flanges)	13 (Hubbed threaded flanges)
11 (Weld-neck flanges)	21 (Integral flanges)

EN 1092-1 PN100 Flanges

DN	Mating dimensions					Outside Diameter of Neck	Bore Diameter	Flange thickness				Diameter of Shoulders	Length			Neck diameters			Corner Radius	Wall thickness					
	Outside Diameter	Diameter of Bolt Circle	Diameter of Bolt Hole	Bolting				A	B1	C1	C2		C3	C4	G max	H1	H2	H3			N1	N2	N3	R1	S
	D	K	L	No	Size																				
	Flange type																								
	01, 05, 11, 12, 13, 21					11 21***	01 12	01	11 12 13	21	05	05	12 13	11	11	11	12 13	21	11 12 13 21	11					
10	100	70	14	4	M12	17.2	18.0	20	20	20	20	-	28	45	6	32	40	40	4	See "Wall thickness and end preparation"					
15	105	75	14	4	M12	21.3	22.0	20	20	20	20	-	28	45	6	34	43	45	4						
20	130	90	18	4	M16	26.9	27.5	22	22	22	22	-	30	48	8	42	52	50	4						
25	140	100	18	4	M16	33.7	34.5	24	24	24	24	-	32	58	8	52	60	61	4						
32	155	110	22	4	M20	42.4	43.5	24	24	26	24	-	32	60	8	62	68	68	6						
40	170	125	22	4	M20	48.3	49.5	26	26	28	26	-	34	62	10	70	80	82	6						
50	195	145	26	4	M24	60.3	61.5	28	28	30	30	-	36	68	10	90	95	96	6						
65	220	170	26	8	M24	76.1	77.5	30	30	34	30	45	40	76	12	108	118	118	6						
80	230	180	26	8	M24	88.9	90.5	34	32	36	32	60	44	78	12	120	130	128	8						
100	265	210	30	8	M27	114.3	116.0	36	36	40	36	80	52	90	12	150	158	150	8						
125	315	250	33	8	M30	139.7	141.5	42	40	40	40	105	56	105	12	180	188	185	8						
150	355	290	33	12	M30	168.3	170.5	48	44	44	44	130	60	115	12	210	225	216	10						
200	430	360	36	12	M33	219.1	221.5	60	52	52	52	180	-	130	16	278	-	278	10						
250	505	430	39	12	M36	273.0	276.5	72	60	60	60	210	-	157	18	340	-	340	12						
300	585	500	42	16	M39	323.9	327.5	84	68	68	68	260	-	170	18	400	-	407	12						
350	655	560	48	16	M45	355.6	359.5	95	74	74	74	300	-	189	20	460	-	460	12						
400	715	620	48	16	M45	406.4	411.0	80	60	60	60	360	-	160	20	475	-	490	12						
500	870	760	56	20	M52	508.0	513.5	To be specified by the purchaser																	

*** For flanges type 21 the outside hub diameter approximately corresponds to the outside pipe diameter.

Note 1: Dimensions N1, N2 and N3 are measured at the intersection of the hub draft angle and the back face of the flange.

Note 2: The centre portion of the face of a flange type 05 need not be machined provided that the diameter of the un-machined portion does not exceed the recommended diameter for G max.

Note 3: For d1 dimensions see document "Flange Facing Dimensions EN 1092-1".

EN 1092-1 PN160 Flanges

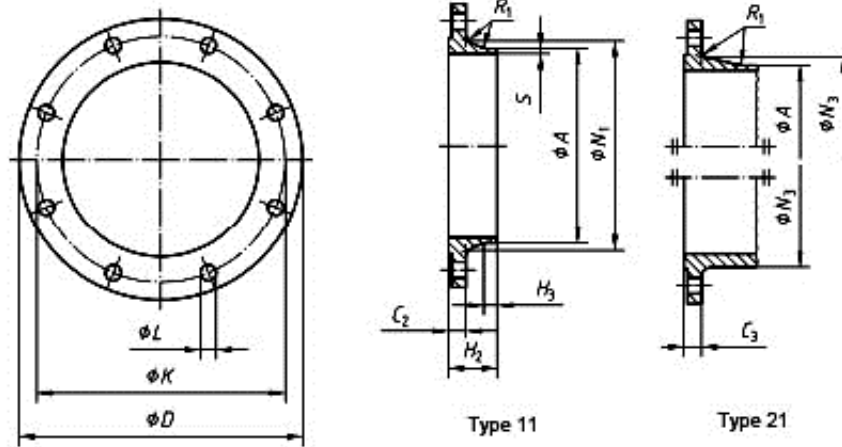

Flange type (typ) as in EN 1092-1	
11 (Weld-neck flanges)	21 (Integral flanges)

DN	Mating dimensions					Outside Diameter of Neck	Flange thickness		Length		Neck diameters		Corner Radius		Wall thickness
	Outside Diameter	Diameter of Bolt Circle	Diameter of Bolt Hole	Bolting			C2	C3	H2	H3	N1	N3	R1		
	D	K	L	No	Size		A								
	Flange type														
	11, 21					11 21***	11	21	11	11	11	21	11	21	11
10	100	70	14	4	M12	17.2	20	20	45	6	32	40	4	4	2.0
15	105	75	14	4	M12	21.3	20	20	45	6	34	45	4	4	2.0
25	140	100	18	4	M16	33.7	24	24	58	8	52	61	4	4	2.9
40	170	125	22	4	M20	48.3	28	28	64	10	70	82	6	4	3.6
50	195	145	26	4	M24	60.3	30	30	75	10	90	96	6	4	4.0
65	220	170	26	8	M24	76.1	34	34	82	12	108	118	6	5	5.0
80	230	180	26	8	M24	88.9	36	36	86	12	120	128	8	5	6.3
100	265	210	30	8	M27	114.3	40	40	100	12	150	150	8	5	8.0
125	315	250	33	8	M30	139.7	44	44	115	14	180	184	8	6	10.0
150	355	290	33	12	M30	168.3	50	50	128	14	210	224	10	6	12.5
200	430	360	36	12	M33	219.1	60	60	140	16	278	288	10	8	16.0
250	515	430	42	12	M39	273.0	68	68	155	18	340	346	12	8	20.0
300	585	500	42	16	M39	323.9	78	78	175	18	400	414	12	10	22.2

*** For flanges type 21 the outside hub diameter approximately corresponds to the outside pipe diameter.

Note 1: Dimensions N1 and N3 are measured at the intersection of the hub draft angle and the back face of the flange.

Note 2: For d1 dimensions see document "Flange Facing Dimensions EN 1092-1".

EN 1092-1 PN250 Flanges

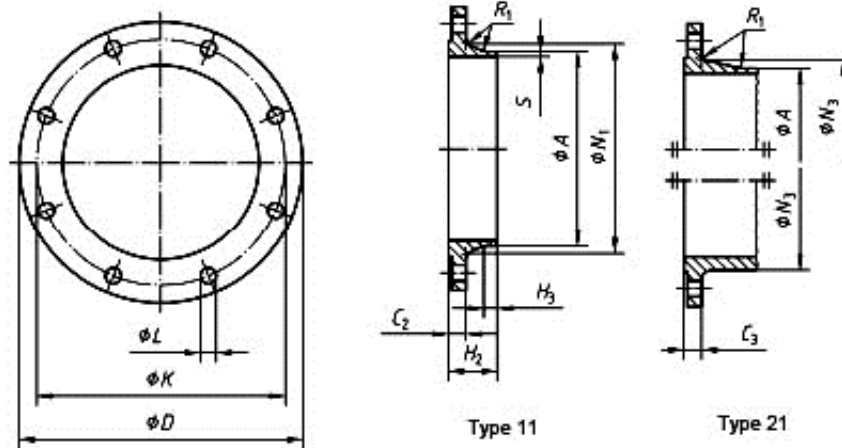

Flange type (typ) as in EN 1092-1	
11 (Weld-neck flanges)	21 (Integral flanges)

DN	Mating dimensions					Outside Diameter of Neck	Flange thickness		Length		Neck diameters		Corner Radius		Wall thickness
	Outside Diameter	Diameter of Bolt Circle	Diameter of Bolt Hole	Bolting			C2	C3	H2	H3	N1	N3	R1	S	
	D	K	L	No	Size		A								
	Flange type														
	11, 21					11 21***	11	21	11	11	11	21	11	21	11
10**	125	85	18	4	M16	-	-	24	-	-	-	46	-	4	-
15	130	90	18	4	M16	21.3	26	26	60	6	48	52	4	4	2.6
25	150	105	22	4	M20	33.7	28	28	65	8	60	63	4	4	3.6
40	185	135	26	4	M24	48.3	34	34	80	10	84	90	6	4	5.0
50	200	150	26	8	M24	60.3	38	38	85	10	95	102	6	5	6.3
65	230	180	26	8	M24	76.1	42	42	95	12	124	125	6	5	8.0
80	255	200	30	8	M27	101.6	46	46	102	12	136	142	8	6	11.0
100	300	235	33	8	M30	127.0	54	54	120	14	164	168	8	6	14.2
125	340	275	33	12	M30	152.4	60	60	140	16	200	207	8	6	16.0
150	390	320	36	12	M33	177.8	68	68	160	18	240	246	10	8	17.5
200	485	400	42	12	M39	244.5	82	82	190	25	305	314	10	8	25.0
250	585	490	48	16	M45	298.5	100	100	215	30	385	394	12	10	32.0
300*	690	590	52	16	M48	-	-	120	-	-	-	480	-	10	-

* For flange type 21.

** For flange type 11 use flanges PN320.

*** For flange type 21 the outside hub diameter approximately corresponds to the outside pipe diameter.

Note 1: Dimensions N1 and N3 are measured at the intersection of the hub draft angle and the back face of the flange.

Note 2: For d1 dimensions see document "Flange Facing Dimensions EN 1092-1".

EN 1092-1 PN320 Flanges

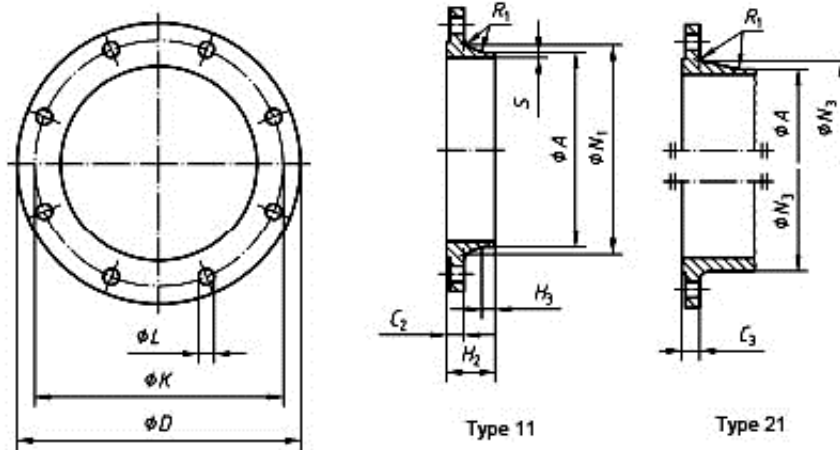

Flange type (typ) as in EN 1092-1	
11 (Weld-neck flanges)	21 (Integral flanges)

DN	Mating dimensions					Outside Diameter of Neck A	Flange thickness		Length		Neck diameters		Corner Radius	Wall thickness S	
	Outside Diameter D	Diameter of Bolt Circle K	Diameter of Bolt Hole L	Bolting			C2	C3	H2	H3	N1	N3	R1		
				No	Size										
	Flange type														
	11, 21						11	21	11	11	11	21	11	21	11
10	125	85	18	4	M16	17.2	24	24	58	6	44	46	4	4	2.6
15	130	90	18	4	M16	21.3	26	26	60	6	48	52	4	4	3.2
25	160	115	22	4	M20	33.7	34	34	78	8	68	72	4	4	5.0
40	195	145	26	4	M24	48.3	38	38	88	10	92	96	6	5	6.3
50	210	160	26	8	M24	63.5	42	42	100	10	106	110	6	5	8.0
65	255	200	30	8	M27	88.9	51	51	120	12	138	137	6	6	11.0
80	275	220	30	8	M27	101.6	55	55	130	14	156	160	8	6	12.5
100	335	265	36	8	M33	133.0	65	65	145	16	186	190	8	8	16.0
125	380	310	36	12	M33	168.3	75	75	175	20	230	235	8	8	20.0
150	425	350	39	12	M36	193.7	84	84	195	25	265	266	10	10	25.0
200	525	440	42	16	M39	244.5	103	103	235	30	345	350	10	10	30.0
250	640	540	52	16	M48	323.9	125	125	300	40	428	432	12	10	40.0

*** For flanges type 21 the outside hub diameter approximately corresponds to the outside pipe diameter.

Note 1: Dimensions N1 and N3 are measured at the intersection of the hub draft angle and the back face of the flange.

Note 2: For d1 dimensions see document "Flange Facing Dimensions EN 1092-1".

EN 1092-1 PN400 Flanges

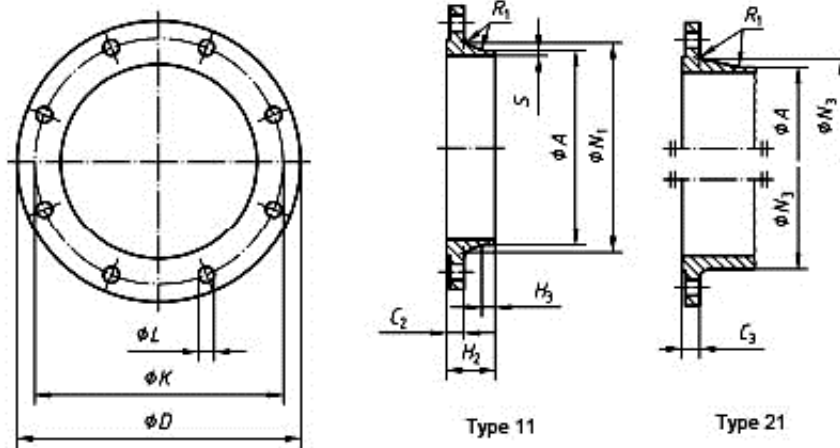

Flange type (typ) as in EN 1092-1	
11 (Weld-neck flanges)	21 (Integral flanges)

DN	Mating dimensions					Outside Diameter of Neck	Flange thickness		Length		Neck diameters		Corner Radius	Wall thickness	
	Outside Diameter	Diameter of Bolt Circle	Diameter of Bolt Hole	Bolting			C2	C3	H2	H3	N1	N3	R1		
	D	K	L	No	Size										A
	Flange type														
	11, 21					11 21***	11	21	11	11	11	21	11	21	11
10	125	85	18	4	M16	17.2	28	28	65	8	48	48	4	4	3.6
15	145	100	22	4	M20	26.9	30	30	68	8	56	57	4	4	5.0
25	180	130	26	4	M24	42.4	38	38	90	10	82	81	4	5	7.1
40	220	165	30	4	M27	60.3	48	48	110	12	106	105	6	5	10.0
50	235	180	30	8	M27	76.1	52	52	120	15	120	120	6	6	12.5
65	290	225	33	8	M30	101.6	64	64	135	18	158	158	6	6	16.0
80	305	240	33	8	M30	114.3	68	68	150	20	174	174	8	8	17.5
100	370	295	39	8	M36	139.7	80	80	175	25	216	216	8	8	22.2
125	415	340	39	12	M36	193.7	92	92	200	30	258	259	8	10	30.0
150	475	390	42	12	M39	219.1	105	105	225	35	302	302	10	10	35.0
200	585	490	48	16	M45	273.0	130	130	280	40	388	388	10	10	40.0

*** For flanges type 21 the outside hub diameter approximately corresponds to the outside pipe diameter.

Note 1: Dimensions N1 and N3 are measured at the intersection of the hub draft angle and the back face of the flange.

Note 2: For d1 dimensions see document "Flange Facing Dimensions EN 1092-1".